

JS-MD 3 RES

Aircraft Flight Manual





JS-MD 3 RES AIRCRAFT FLIGHT MANUAL

Type:	JS-MD Single
Model:	JS-MD 3 RES
Marketing name:	JS-3 RES
Serial number:	
Registration number:	
Document number:	MD11-AFM-00-001

Title:	JS-MD 3 RES Aircraft Flight Manual
Issue	01
Date of issue	14 March 2023
Created by	Uys Jonker <small>Digitally signed by Uys Jonker Date: 2023.03.29 17:18:44 +02'00'</small>
Release by HOA	 <small>Michael Schwarz 2023.03.30 14:47:11 +02'00'</small>

The technical content of this document is approved under the authority of the DOA ref. EASA.21J.603.

Sections 2, 3, 4 and 5.2 are approved by the EASA through EASA.A.616.

Copyright ©:

*M&D Flugzeugbau GmbH & Co.KG
Streeker Straße 5b
D-26446 Friedeburg*

-All rights reserved-

Intentionally left blank

0 Document Management

0.1 Record of revision

Issue	Date	Reason for Change
00	30.10.2021	Initial Issue
01	14.03.2023	Installed RES system data and limitations added / amended Aerotow assisted self-launch procedures moved to supplement Added graph - main water tanks loading vs moment arm Removed reference to dummy or fuselage weights Recommended airspeeds for approach amended to speeds with airbrakes always extended

0.2 List of effective sections

Section	Revision	Date	Number of Pages	Reference
0	00	14.03.2023	6	First Issue
1	00	14.03.2023	6	First Issue
2	00	14.03.2023	20	First Issue
3	00	14.03.2023	14	First Issue
4	00	14.03.2023	32	First Issue
5	00	14.03.2023	6	First Issue
6	00	14.03.2023	18	First Issue
7	00	14.03.2023	34	First Issue
8	00	14.03.2023	8	First Issue
9	00	14.03.2023	2	First Issue
10	00	14.03.2023	2	First Issue
11	00	14.03.2023	2	First Issue
12	00	14.03.2023	2	First Issue

0.4 Table of contents

JS-MD 3 RES AIRCRAFT FLIGHT MANUAL	i
0 Document Management	0-1
0.1 Record of revision	0-1
0.2 List of effective sections	0-2
0.3 Record of amendments	0-3
0.4 Table of contents	0-4
1 General	1-7
1.1 Introduction	1-7
1.2 Certification basis	1-7
1.3 Warnings, cautions and notes	1-8
1.4 Descriptive data	1-9
1.5 Technical data	1-10
1.6 Three-view drawing	1-12
2 Limitations	2-1
2.1 Introduction	2-1
2.2 Airspeed limits	2-2
2.3 Power plant batteries	2-5
2.4 Power plant instrument markings	2-5
2.5 Mass	2-6
2.6 Centre of Gravity	2-8
2.7 Approved manoeuvres	2-10
2.8 Flight load factor limits	2-11
2.9 Flight crew	2-12
2.10 Types of operation	2-13
2.11 Minimum equipment list	2-14
2.12 Aerotow and winch launching	2-15

2.13	Other limitations	2-17
2.14	Limitations placards.....	2-20
3	Emergency procedures	3-1
3.1	Introduction.....	3-1
3.2	Canopy jettison.....	3-1
3.3	Bailing out.....	3-2
3.4	Stall recovery.....	3-3
3.5	Spin recovery	3-4
3.6	Spiral dive recovery.....	3-5
3.7	Excessive sideslip recovery	3-6
3.8	Propulsion system failure	3-7
3.9	Propulsion system fire.....	3-7
3.10	Electrical fire.....	3-7
3.11	Other emergencies.....	3-9
4	Normal operating procedures.....	4-1
4.1	Introduction.....	4-1
4.2	Rigging and de-rigging	4-1
4.3	Daily inspections	4-8
4.4	Pre-flight check.....	4-13
4.5	Normal procedures and recommended speeds.....	4-15
5	Performance	5-1
5.1	Introduction.....	5-1
5.2	Approved data	5-1
5.3	Non-approved information.....	5-4
6	Weight and balance	6-1
6.1	Introduction.....	6-1
6.2	Weight and balance record	6-1
6.3	Permitted payload-range and CG envelope.....	6-4

6.4	Optimisation of centre of gravity.....	6-11
7	System description	7-1
7.1	Introduction.....	7-1
7.2	Cockpit controls.....	7-1
7.3	Landing gear system.....	7-12
7.4	Seats and safety harness.....	7-13
7.5	Pneumatic system.....	7-14
7.6	Airbrake system.....	7-16
7.7	Baggage compartment.....	7-17
7.8	Water ballast system.....	7-18
7.9	Power plant.....	7-27
7.10	Fuel system.....	7-27
7.11	Electrical system.....	7-28
7.12	Miscellaneous equipment.....	7-33
8	Handling and maintenance	8-1
8.1	Aircraft inspection periods.....	8-2
8.2	Ground handling.....	8-3
8.3	Cleaning and care.....	8-5
8.4	Long-term storage.....	8-8
9	Supplements.....	9-1
9.1	Introduction.....	9-1
9.2	List of ancillary equipment.....	9-1
10	Service bulletins.....	10-1
11	STCs and minor change approvals.....	11-1
12	Contact.....	12-1
12.1	Type Certificate Holder.....	12-1
12.2	Manufactured by.....	12-1

1 General

1.1 Introduction

This Flight Manual has been prepared to provide pilots and instructors with all the information required for safe and efficient operation of the JS-MD 3 RES. All the data that is required by the Airworthiness Requirement CS-22 to be provided to the pilot is contained in this manual. It also contains supplementary data supplied by the aircraft manufacturer.

The JS-MD 3 RES is a high-performance aircraft not intended for training purposes. Even though it possesses excellent performance and handling qualities, it can only be flown by a skilled pilot who complies with the limitations and recommendations set out in this manual.

If a Retractable Electric System (RES) is fitted, use this manual in combination with the latest approved JS-MD 3 RES Flight Manual Supplement.

The marketing name for model JS-MD 3 RES is the JS-3 RES, and referred to in this manual as the JS-3 RES.

1.2 Certification basis

This aircraft, with production designation JS-MD Single model JS-MD 3 RES has been approved by the European Aviation Safety Agency (EASA) in accordance with CS-22 Amendment 2 and the Type Certificate No. EASA.A.616 has been issued accordingly.

The JS-MD 3 RES is of category U (Utility).

1.3 Warnings, cautions and notes

The following definitions apply to warnings, cautions and notes used in this Flight Manual.

WARNING: This means that the non-observation of the corresponding procedure leads to an immediate or important degradation in flight safety.

CAUTION: This means that the non-observation of the corresponding procedure leads to a minor or to a longer-term degradation in flight safety.

NOTE: Draws attention to any special item not directly related to safety but which is important or unusual.

1.4 Descriptive data

The JS-MD 3 RES is a high-performance single-seat aircraft of conventional layout with a T-tail. Two wingspan configurations (15 m and 18 m) can be selected, both of which feature full-span flaperons.

The cockpit is designed to protect the pilot in the event of a crash. Safety features include a crumple zone in the forward structure. The wing structure consists of spar caps made of carbon fibre rovings and skins of carbon fibre fabric. The wings are connected with a tongue and fork arrangement, secured with one main pin. The airbrakes are a triple blade design on the upper surface of the wing.

Boundary layer control is achieved on the main wing bottom surfaces, the horizontal stabilizer and vertical fin. All control surface hinge gaps are sealed with Mylar strips and Teflon-coated tape.

The water ballast system consists of two main tanks and two trim tanks in the vertical fin. Each main tank is integral to a wing and can hold approximately 66 litres (or 78 litres optional) of water. The tail ballast tanks consist of an expendable tank of approximately 5.8 litres and non-expendable tanks with a combined capacity of approximately 8.9 litres. The 18 m wing tips feature additional integral tanks, with a capacity of approximately 17 litres each. The landing gear consists of a 5-inch retractable sprung main landing gear with a retractable tail wheel.

All controls are automatically connected during rigging.

The RES, approved for take-off and sustained flight, can be fitted.

1.5 Technical data

Geometry	JS-3 RES 15 m	JS-3 RES 18 m
Wing span	15 m / 49.21 ft	18 m / 59.06 ft
Wing area	8.75 m ² / 94.18 ft ²	9.95 m ² / 107.10 ft ²
Aspect ratio	25.4	32.8
Fuselage length	6.86 m / 22.51 ft	
Fuselage height	1.35 m / 4.42 ft	
Weight	JS-3 RES 15 m	JS-3 RES 18 m
Maximum weight (with 0 / 1 RES HV battery)	525 kg / 1157 lbs	600 kg / 1322 lbs
Maximum weight (with 2 RES HV batteries)	525 kg / 1157 lbs	575 kg / 1267 lbs
Approximate empty weight (without RES)	284 kg / 626 lbs	296 kg / 653 lbs
Approximate empty weight (RES, no HV batteries)	321 kg / 681 lbs	343 kg / 705 lbs
Minimum wing load (70kg pilot, no HV batteries)	43.3 kg/m ² / 8.89 lb/ft ²	39.6 kg/m ² / 8.11 lb/ft ²
Maximum wing load	60.0 kg/m ² / 12.28 lb/ft ²	60.3 kg/m ² / 12.35 lb/ft ²
Glide performance	JS-3 RES 15 m	JS-3 RES 18 m
Best glide ratio	50	57
Best glide speed at MTOM flap setting 4 (9° - 13.5°)	125 km/h 67.5 kts	120 km/h 64.8 kts
Best glide speed at 450 kg flap setting 4 (9° - 13.5°)	110 km/h 59.4 kts	105 km/h 56.7 kts
Sink rate (200 km/h / MTOM)	1.57 m/s 309 ft/min	1.60 m/s 315 ft/min

Table 1-1 Technical data

1.6 Three-view drawing

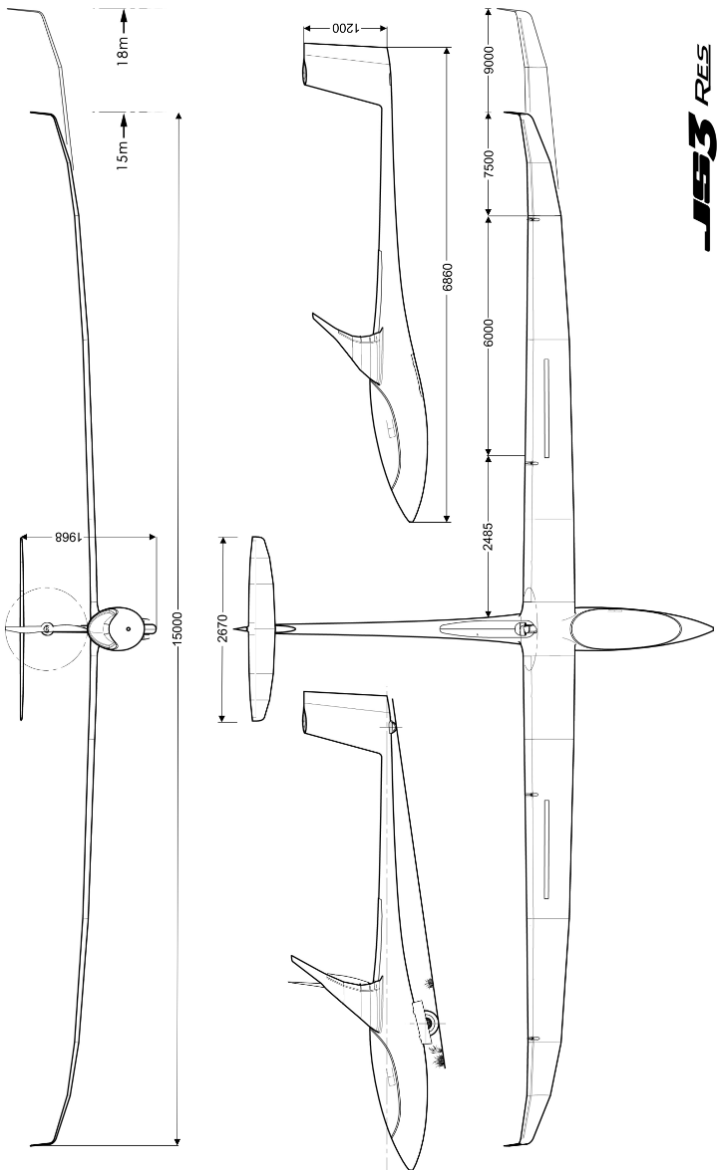

JS-3 RES

Figure 1-1 JS-3 RES

Intentionally left blank

2 Limitations

2.1 Introduction

Section 2 includes operating limitations, instrument markings and basic placards necessary for safe operation of the aircraft, its propulsion system (if fitted), standard systems and standard equipment.

The limitations included in this section have been approved by the EASA.

2.2 Airspeed limits

Speed limitations and their operational significance are shown in Table 2-1 below:

Speed		IAS	Remarks
V_{NE}	Never exceed speed	270 km/h 145.8 kts	Do not exceed this speed in any operation and do not use more than 1/3 maximum control deflection.
V_{RA}	Rough air speed	195 km/h 105.2kts	Do not exceed this speed except in smooth air, and then only with caution. Examples of rough air are lee-wave rotor, thunderclouds etc.
V_A	Manoeuvring speed	195 km/h 105.2 kts	Do not make full or abrupt control movements above this speed, because under certain conditions the aircraft may be overstressed by full control movement.
V_{FE}	Maximum flap extended speed	See Table 2-2	Do not exceed these speeds with the given flap setting.
V_W	Maximum winch launching speed	150 km/h 80.9 kts	Do not exceed this speed during winch or auto tow launching
V_T	Maximum aerotow speed	180 km/h 97.1 kts	Do not exceed this speed during aerotow.
V_{LO}	Maximum landing gear operating speed	180 km/h 97.1 kts	Do not extend or retract the landing gear above this speed.
V_{PO}	Maximum power plant extension & retraction speed	Refer to JS-MD 3 RES Flight Manual Supplement.	
V_{PE}	Maximum speed with the power plant extended		

Table 2-1 Airspeed Limits

Table 2-2 below lists the maximum allowable airspeeds for each flap setting:

Flap setting	Deflection (°)	V _{FE}	
		15 m	18 m
1	-3°	270 km/h / 145.8 kts	
2	+0°		
3	+5°	230 km/h / 124.1 kts	
4	+13.5°	165 km/h / 89.0 kts	
5	+16.6°	165 km/h / 89.0 kts	
L	+20°	160 km/h / 86.3 kts	

Table 2-2 Airspeeds for flap settings

The maximum allowable airspeeds for each flap setting are indicated on the airspeed indicator (ASI) with white triangles next to the flap position number, as indicated in Figure 2-1 (ASI in km/h) and Figure 2-2 (ASI in knots).



Figure 2-1 ASI in km/h

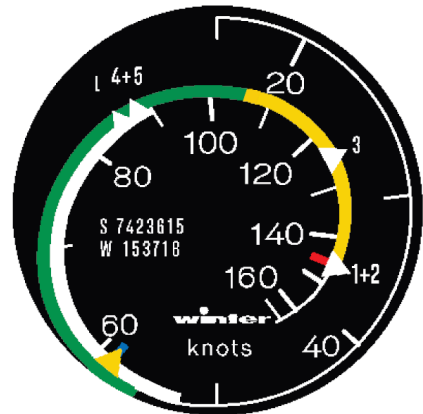

Figure 2-2 ASI in knots

2.2.1.1 Airspeed indicator markings

The airspeed indicator markings and their colour code significance are given in Table 2-3:







Marking	IAS		Significance
	15 m	18 m	
White Arc		97 to 160 km/h 52.4 to 86.3 kts	Positive Flap Operating Range. (Lower limit is $1.1 V_{SO}$ in landing configuration at maximum weight. Upper limit is maximum speed permissible with flaps extended positive)
Green Arc		103 to 195 km/h 55.7 to 105.3 kts	Normal Operating Range. (Lower limit is $1.1 V_{S1}$ at maximum weight and most forward CG with flaps neutral. Upper limit is rough air speed.)
Yellow Arc		195 to 270 km/h 105.3 to 145.8 kts	Manoeuvres must be conducted with caution and only in smooth air.
Red Line		270 km/h 145.8 kts	Maximum speed limit for all operations.
Blue Line		110km/h 59.3 kts	Best rate-of-climb speed V_Y (if RES is fitted)
Yellow Triangle		110 km/h 59.3 kts	Approach speed at maximum weight without water ballast.

Table 2-3 Airspeed indicator markings

NOTE: V_{SO} is defined as the stall speed at maximum weight, in the landing configuration, with the CG in the most unfavourable position. See CS 22.49.

NOTE: V_{S1} is defined as the stall speed at maximum weight, in a specific selected configuration, with the CG in the most unfavourable position. See CS 22.49.

2.3 Power plant batteries

Refer to section 8.2.3 in the JS-MD 3 RES Flight Manual Supplement.

2.4 Power plant instrument markings

Refer to section 2.3 in the JS-MD 3 RES Flight Manual Supplement.

2.5 Mass

The mass limitations for the JS-3 RES are given in Table 2-4:

Mass definition	Mass limits	
	15 m	18 m
Maximum Take-Off Mass (with 0 / 1 HV battery)	525 kg 1157 lbs	600 kg 1323 lbs
Maximum Take-Off Mass (with 2 HV batteries)	525 kg 1157 lbs	575 kg 1267 lbs
Maximum Take-Off Mass without water ballast	452 kg 996 lbs	500 kg 1102 lbs
Maximum Take-Off Mass for winch launching	525 kg 1157 lbs	600 kg 1323 lbs
Maximum Mass of non-lifting parts at MTOM	340 kg 749 lbs	340 kg 749 lbs
Maximum mass for cloud flying / aerobatics	418 kg 921 lbs	418 kg 921 lbs

Table 2-4 Mass Limitations

Table 2-5 displays the reduction in allowable non-lifting parts mass for take-off masses below the maximum allowed masses.

Aircraft mass	Non-lifting parts mass structural limit	
	15 m	18 m
350 kg 771 lbs	210 kg 463 lbs	200 kg 440 lbs
490 kg 1080 lbs	335 kg 738 lbs	-
504 kg 1111 lbs	-	335 kg 738 lbs
MTOM	340 kg 749 lbs	340 kg 749 lbs

Table 2-5 Non-lifting parts mass structural limit

NOTE: Increase the take-off mass by adding water in the tips to take advantage of a higher non-lifting part mass.

WARNING: Only soft items such as canopy covers, and jackets may be stored in the baggage compartment. This is necessary to prevent injury to the pilot during an emergency landing.

2.6 Centre of Gravity

Table 2-6 displays the allowable Centre of Gravity (CG) range for the JS-3 RES in the 15 m and 18 m configurations:

Centre of Gravity range (in flight)	Distance from datum	
	15 m	18 m
Most forward CG location (325 kg to 400 kg)	270 mm 10.63 in	270 mm 10.63 in
Most forward CG location (at MTOM)	305 mm 12.01 in	315 mm 12.40 in
Most aft CG location	390 mm 15.35 in	398 mm 15.66 in

Table 2-6 Allowable CG range

The datum is defined as the wing leading edge at the wing root rib, i.e. on the wing immediately outboard of the wing-fuselage fairing. The correct aircraft attitude for weighing is defined as with the aft fuselage boom forward of the fin positioned at a gradient of 1000:18, as illustrated in Figure 2-3.

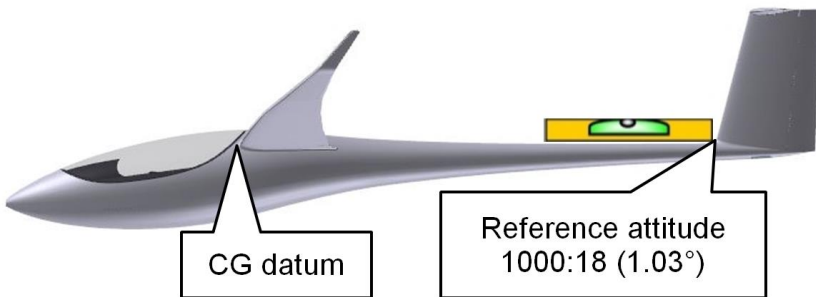

Figure 2-3 CG Datum

Table 2-7 gives the forward and rear CG limits (no payload) for different empty masses that will allow a cockpit range of 70 kg to 115 kg.

Empty mass		Empty Centre of Gravity range							
		Forward limit To allow a maximum cockpit load of 115 kg (253 lbs)				Rear limit To allow a minimum cockpit load of 70 kg (154 lbs)			
kg	lbs	15 m		18 m		15 m		18 m	
300	661.4	628	mm	628	mm	632	mm	641	mm
		24.7	in	24.7	in	24.9	in	25.3	in
310	684.0	621	mm	621	mm	624	mm	634	mm
		24.5	in	24.5	in	24.6	in	24.9	in
320	706.1	615	mm	615	mm	616	mm	626	mm
		24.2	in	24.2	in	24.3	in	24.7	in
330	728.1	609	mm	609	mm	610	mm	619	mm
		24.0	in	24.0	in	24.0	in	24.4	in
340	750.2	603	mm	603	mm	603	mm	613	mm
		23.7	in	23.7	in	23.7	in	24.1	in

Table 2-7 Empty Centre of Gravity range

If the calculated empty CG falls outside of this envelope, the minimum and maximum cockpit loads must be determined using the formula given in the JS-MD 3 RES Aircraft Maintenance Manual 08-10-00.

2.7 Approved manoeuvres

This aircraft is certified in the Utility category (U). The following aerobatic manoeuvres are permitted in the 15 m and 18 m configuration:

- Lazy eight
- Chandelle
- Steep turns
- Positive loops
- Stall turns
- Spins

Refer to Section 4.5.11 for the recommended entry speeds for each manoeuvre.

2.8 Flight load factor limits

The minimum and maximum approved manoeuvring load factors are given in Table 2-8 below:

Condition	IAS		Load factor
	15 m	18 m	
Maximum positive manoeuvre	195 km/h 105 kts		+ 5.3
Maximum negative manoeuvre	195 km/h 105 kts		- 2.65
Maximum positive manoeuvre	270 km/h 145.8 kts		+ 4.0
Maximum negative manoeuvre	270 km/h 145.8 kts		- 1.5
Maximum positive manoeuvre with airbrakes open	270 km/h 145.8 kts		+ 3.5
Maximum positive manoeuvre with flaperons in landing configuration	160 km/h 86 kts		+ 4.0

Table 2-8 Manoeuvring load factors

2.9 Flight crew

The minimum and maximum pilot mass is indicated on the cockpit placard or Placard Booklet.

- Minimum cockpit mass: 70 kg (155 lbs)
- Maximum cockpit mass: 115 kg (253 lbs)

CAUTION: If the measured empty CG is not within the normal empty mass CG range, the minimum and maximum cockpit mass must be calculated and the cockpit placard values must be corrected accordingly.

Pilots with a weight below the minimum cockpit mass must add cockpit ballast according to the CG calculations as explained in Section 6.

NOTE: The term “cockpit mass” includes the pilot, parachute, baggage and any other temporary equipment.

Contact the manufacturer or approved service station if assistance is required.

2.10 Types of operation

The JS-3 RES is approved for:

- VFR day operation
- Cloud flying in 15 m and 18 m configuration without water ballast where national regulations permit.

NOTE: For cloud flying the take-off mass must not exceed 418 kg (921 lbs), as listed in Section 2.5, and the pylon must be retracted (if fitted).

Refer to Section 2.11 for the minimum equipment required for cloud flying.

2.11 Minimum equipment list

Instruments and other equipment on the minimum equipment list must be approved. Refer to the accessory approval section in the JS-MD 3 RES Aircraft Maintenance Manual for details.

The minimum equipment:

- Pitot-static type airspeed indicator, scale 50 to 300 km/h (27.0 to 161.9 kts), colour markings in accordance with Section 2.2 of this manual
- Altimeter
- 4-Point symmetrical seat harness
- Fixed Operating placards or Placard Booklet
- Control surface gap seals (Mylar seals) on all control surfaces

Additional instrumentation required when flying with water ballast:

- Instrumentation indicating outside air temperature with the probe installed in the fuselage nose.

Additional instrumentation required for cloud flying:

- Turn and bank indicator or artificial horizon,
- Variometer to indicate vertical speed.

Additional instrumentation required if RES is fitted:

Refer to JS-MD 3 RES Flight Manual Supplement.

2.12 Aerotow and winch launching

Maximum approved towing speeds and maximum weak link ratings for the JS-3 RES are listed in Table 2-9.

Launch method	Maximum speed	Maximum weak link rating
Winch or ground launch	150 km/h / 80.9 kts	750 daN (E.g. Tost weak link #3, Red)
Aerotow	180 km/h / 97.1 kts	600 daN (E.g. Tost weak link #4, Blue)

Table 2-9 Aerotow and winch launching

For aerotow launching:

Tow rope length	15 m & 18 m Configurations
Approved	40 to 60 m (131 to 197 ft)
Recommended	45 to 55 m (148 to 180 ft)

Table 2-10 Tow rope length

NOTE: Only textile ropes may be used for aerotow launching.

Configuration	Minimum safe launch speed		Recommended launch speed	
	15m	18m	15m	18m
Empty	115 km/h / 62.0 kts		130 km/h / 70.2 kts	
MTOW	125 km/h / 67.5 kts		140 km/h / 75.6 kts	

Table 2-10 Aerotow limitations and recommended speeds

For aerotow assisted launching:

Refer to Section 2.7 in the JS-MD 3 RES Flight Manual Supplement.

2.13 Other limitations

2.13.1 Limitations when flying with water ballast

Intentional manoeuvres not permitted when flying with water ballast or if RES HV batteries are fitted:

- Loops
- Chandelles
- Lazy eights
- All aerobatic manoeuvres listed in the aerobatic category
- Intentional spins

Cloud flying is not permitted when flying with water ballast.

2.13.2 Temperature restrictions without water ballast

Flights conducted in conditions below -30 °C are prohibited. When the outside air temperature is less than -30 °C, a descent to lower altitudes (higher temperatures) must be conducted.

WARNING: Icing of even small amounts of the water ballast may cause structural damage to the wing tanks and fin structures.

WARNING: Sub-zero temperatures may result in the controls freezing up. Move the controls, including the airbrakes, regularly to reduce the risk of control freezing.

2.13.3 Temperature restrictions when carrying water

Flights with water ballast are prohibited in conditions where there is a risk of icing. When the outside air temperature is below 0 °C (32 °F), the water ballast must be dumped or descent to lower altitudes (higher temperatures) must be conducted. Flying in temperatures below freezing with water in the non-expendable tank is not allowed.

WARNING: Icing water ballast may cause structural damage to the wing and fin structures. Avoid flying in icing conditions, or storage of the aircraft with the water tanks filled.

WARNING: Dumped water may freeze at the valve outlets at outside temperature well above the freezing point.

CAUTION: Currently no additives (e.g. anti-freeze) are approved to lower the water freezing point.

2.13.4 Limitations while dumping water ballast

Dumping the water ballast takes approximately five minutes. While dumping, the fuselage static ports may get temporarily blocked by water entering the static ports. This may cause the airspeed indicator to give incorrect readings during descent. These erroneous readings may continue until the main tanks are empty.

CAUTION: Avoid high speed flying (within 30 km/h / 16.2 kts of limit speeds) when the water ballast is being dumped. Monitor the approach speed and approach angle as the actual approach speed may be indicated incorrectly. It is recommended to change to the alternate static port (if fitted) while dumping water.

CAUTION: Ensure the water in the main tanks is dumped before dumping water from the tip tanks.

2.13.5 Limitations of high-speed flight

If there are any indications that an airspeed limit may be exceeded (e.g. when flying in wave rotors, near thunderstorms or other turbulent conditions), extend the airbrakes carefully before exceeding 195 km/h / 105.0 kts. In emergencies the airbrakes may be extended up to V_{NE} , as defined in Section 2.2. Above 250 km/h / 135.0 kts the airbrakes are sucked open after unlocking, resulting in a significant deceleration which may result in pilot induced oscillations (P.I.O.). This effect is least in the negative flap position. When the airbrakes are extended in possible turbulent conditions the Rough Airspeed (V_{RA}) should not be exceeded. Decelerate to 195 km/h / 105.0 kts before closing the airbrakes. The forces acting on the airbrakes at speeds above 220 km/h / 118.8 kts are very high.

WARNING: Although the airbrake damper reduces the deceleration associated with the opening of the airbrakes at high speeds, the negative G's may still result in the pilot's head shattering the canopy if the seat harness straps are not tight. Ensure that the seat harness straps are tight before operating the airbrakes at high speeds.

2.13.6 Altitude limitations

The aircraft is limited to an altitude of 7000 m or 21000 ft Above Mean Sea Level (AMSL).

See Section 4.5.8 for more details.

NOTE: For further placards or information furnished in the Placard Booklet, refer to the Maintenance Manual.

2.14 Limitations placards

Limitation placards can be either fixed against the side walls or instrument panel, or furnished as a single Placard Booklet located against the left-hand cockpit sidewall.

The placard given in Figure 2-4 is fixed to the left sidewall of the cockpit and contains the most important mass and speed limitations.

JS3 RES Limit Airspeeds:			
		kts	km/h
V_{NE} Maximum Speed		145	270
V_A Manoeuvring / V_{RA} Rough Air		105	195
V_W Winch Launch		81	150
V_T Aero-Tow		97	180
V_{PE} Powerplant Extended		81	150
V_{PO} Powerplant Extension-Retraction		81	150
V_{LO} Max Landing Gear Operating Speed		97	180
Maximum Mass:			
	HV batteries	lbs	kg
15m	0 / 1	1157	525
	2	1157	525
18m	0 / 1	1322	600
	2	1267	575
Tyre Pressure			
	Main Wheel 15m	psi	bar
		36.3	2.5
	Main Wheel 18m	50.8	3.5
	Tail Wheel 15/18m	36.3	2.5
Approved Aerobatic Manoeuvres (15m and 18m):			
(Restrictions in Flight Manual) Positive Loops; Chandelles; Lazy Eights; Stall Turns; Spins			

Figure 2-4 Limitation placard (JS-MD 3 RES)

Refer to section 2.9 in the JS-MD 3 RES Flight Manual Supplement for the additional placards required when operating the RES.

The calculated minimum and maximum cockpit mass must be entered with a permanent marker on the cockpit placard (as illustrated in Figure 2-5) and must correlate with the values in the mass and balance report.

COCKPIT LOADS: Min cockpit weights	15m Number of batteries installed			18m Number of batteries installed		
	None	1	2	None	1	2
Non-expendable tail tank						
0 L						
8.9 L						
Max cockpit weight:						
Aircraft empty weight:						

Figure 2-5 Cockpit masses placard

Figure 2-6 gives the placard to be displayed in the baggage compartment, refer to section 7.7 for more information.



Figure 2-6 Baggage compartment placard

NOTE: Refer to the JS-MD 3 RES Aircraft Maintenance Manual for all the required fixed placards or the equivalent Placard Booklet.

3 Emergency procedures

3.1 Introduction

Section 3 provides checklists and amplified procedures for handling emergencies that may occur.

3.2 Canopy jettison

To jettison the canopy, pull both left and right canopy jettison latches as far as possible and push the canopy upward with the latches.

The jettison latches are labelled or engraved as shown in the pictures below. Figure 3-1 illustrates the placard for canopy jettison.



Figure 3-1 Canopy jettison placard

Figure 3-2 illustrates the position of the right-hand jettison handle in the cockpit.



Figure 3-2 Canopy jettison handle

3.3 Bailing out

The bailing out procedure is as follows:

1. Jettison the canopy as described in Section 3.2.
2. Release the safety harness.
3. To exit, lift out of the cockpit seat pan using the cockpit rim and push away from the aircraft to avoid striking the tail surfaces (and if possible, try to dive underneath the wing).
4. Deploy the parachute in accordance with the manufacturer's instructions.

CAUTION: Due to the JS-3 RES's high maximum airspeed and because extremely high airspeeds can build up very quickly following a mid-air collision, it is recommended to use a parachute approved for speeds up to 400 km/h.

3.4 Stall recovery

The JS-3 RES has very mild stall properties recognisable by the following:

- The nose is in a higher than normal attitude relative to the horizon.
- Slight buffeting approximately 2 km/h before the stall.
- Airspeed indicator starts fluctuating near the stall.
- A slight increase in the sink rate.
- Aileron effectiveness decreases considerably.

The stall recovery procedure is to release the pressure on the control stick and move it towards the neutral position.

CAUTION: During stalled flight, if the angle of attack is increased by further pulling back on the stick, a wing drop may occur. This asymmetric stall may result in a spin if incorrect stall recovery procedures are used.

NOTE: When a stall is initiated by pulling with the nose to a high pitch angle (in excess of 30° above the horizon), the nose may pitch down well below the horizon during the recovery and the altitude loss during recovery may exceed 60 m / 200 ft.

NOTE: When a stall is initiated with 45° bank, and the resulting roll is not counteracted by use of opposite rudder, a loss of altitude exceeding 100 m / 330 ft may occur.

3.5 Spin recovery

Spin recovery is performed using the standard spin recovery procedure:

1. Apply rudder in the opposite direction to the spin rotation.
2. Simultaneously release the elevator back pressure by moving the stick forward to the neutral position.
3. Centralize the rudder when the rotation stops.
4. Gently pull out of the resulting dive.

NOTE: Ailerons should be kept neutral during the recovery process. (However, full aileron deflection in either direction does not have a significant influence on the recovery behaviour).

CAUTION: Move flaps to position 3 during the pull-out if the spin was commenced in flap Position 4, 5 or L to avoid exceeding V_{FE} (Maximum Flap Extended Speed).

CAUTION: Do not use airbrakes during the pull-out of the dive.

WARNING: Intentional spins with water ballast are prohibited.

Altitude loss during recovery is between 100 m and 380 m (330 ft to 1250 ft). The worst recorded case required 380 m / 1250 ft with the CG in the aft position. The spin rotation speed is relatively low, typically five to six seconds per rotation but varies during spinning.

If the spin is entered with a high incident angle, the nose will oscillate in pitch during the first two rotations. After approximately one rotation, the nose will (with very aft CG positions) rise above the horizon before stabilizing in a nose down spin attitude. Pitch oscillation may continue during the spin, especially with aft CG positions.

3.6 Spiral dive recovery

A spiral dive may occur when:

- The aircraft terminates spinning automatically but the pilot continues applying into-spin control inputs, or
- During excessive slip angles with full rudder deflection.

Indications of a spiral dive are a high bank angle, increasing airspeed and a high G-load.

Spiral dive recovery is performed by:

1. Apply the aileron, co-ordinated with the rudder, gently against the direction of the turn until the wings are level with the horizon.
2. When the wings are level, neutralize both aileron and rudder.
3. Gently pull out of the resulting dive.

CAUTION: During the resulting dive take care not to exceed V_{NE} .

3.7 Excessive sideslip recovery

An excessive sideslip may occur when the pilot applies full cross control input.

Although highly unlikely to happen, at a slip angle exceeding 20° (approximately 40° on the yaw string) rudder control forces may reverse if the rudder is sucked into the wake of the stalled fin.

To recover from an excessive slip:

1. Apply opposite rudder against the direction of the yaw.
2. When balanced flight is restored, neutralize both aileron and rudder.

WARNING: If an excessive slip angle is not corrected with opposite rudder input, the secondary effect of yaw may cause the aircraft to roll and enter a spiral dive. It is not possible to prevent roll by applying full opposite aileron during excessive sideslip.

CAUTION: The rudder control input force required to recover from a side slip exceeding 20° is high (approximately 20 daN) and increases if the speed is allowed to build up during the resulting spiral dive. Apply sufficient rudder input to recover from the sideslip to prevent spiral dive.

3.8 Propulsion system failure

Refer to section 5.2 in the JS-MD 3 RES Flight Manual Supplement.

3.9 Propulsion system fire

3.9.1 High Voltage battery fire on the ground

Refer to section 5.3.1 in the JS-MD 3 RES Flight Manual Supplement.

3.9.2 High Voltage battery fire in flight

Refer to section 5.3.2 in the JS-MD 3 RES Flight Manual Supplement.

3.10 Electrical fire

In the event of smoke or fumes coming from the instrument panel, perform the following actions:

1. Switch off the master switch supplying the circuits.
2. If a circuit breaker “pops”, reset only once. This is most likely due to a faulty circuit.
3. Land as soon as possible.

NOTE: Each 12V power supply circuit is protected by a fuse near the battery terminals and each electrical system has a circuit breaker switch on the instrument panel.

3.10.1 Cockpit fire on the ground

Cockpit fires on the ground can be caused when sunlight reflecting from an open canopy is concentrated onto a surface inside the cockpit.

This is easily prevented by keeping the canopy covered when the aircraft is left unattended, or by positioning the aircraft with the nose pointing towards the sun.

In case of a fire, use an aircraft type fire-extinguisher to extinguish the fire.

NOTE: After any electrical emergency or fire, maintenance action is required.

3.11 Other emergencies

3.11.1 Cable failure during winch launch

In case of a cable failure during a winch launch, perform the following actions:

1. Immediately push the stick sufficiently forward to establish a nose-down attitude in order to regain flying speed.
2. Release the cable.
3. Only after adequate flying speed has been regained:
 - Extend the airbrakes and land straight ahead (provided sufficient runway is available), OR
 - Use an abbreviated circuit and carry out a landing on the airfield.

NOTE: If the cable failed during the steepest part of the launch, it is normally necessary to lower the nose well below the horizon to regain flying speed.

NOTE: If the cable fails while close to the ground, gently lower the nose and land normally.

WARNING: Do not open the airbrakes until the airspeed exceeds the normal approach speed.

3.11.2 Flight with asymmetric water ballast load

Asymmetric water ballast load may develop during flight if:

1. A main tank dump valve leaks.
2. One main tank dumps water faster than the other, due to a partial opening valve, or dumping during prolonged unbalanced flight.
3. Only one main tank valve opens during water dumping.

A developing asymmetry is easily recognizable due to the increased roll tendency towards the heavy wing. At low airspeed, a considerable amount of aileron deflection is necessary to keep the wings level.

When a developing asymmetry is observed, perform the following to prevent full asymmetry developing:

1. If a lateral asymmetry is detected but no water was dumped during the flight, there may have been a leak from one tank. The procedure to follow is:
 - Start to dump water.
 - Monitor the change in roll tendency: If the roll tendency reduces, keep dumping until symmetry is restored. Stop dumping immediately if the roll tendency worsens.

If a lateral asymmetry develops while dumping water, one valve might not have opened or opened partially. The procedure to follow is:

- Visually check if water is dumping from both wings (the water trails can be seen below the wings near the fuselage, and at the tips in the 18 m configuration).
- If both valves are dumping, keep dumping until both wings empty.
- If only one valve is dumping water, close the dumping valves immediately to prevent full water ballast asymmetry from developing.

If the asymmetrical load cannot be rectified, the pilot is strongly recommended to:

1. Land at a suitable airport or field as soon as possible.
2. Increase the approach speed by 10 km/h or 5.4 kts.
3. Avoid any operation near stall speeds.
4. Avoid turns in the landing flap configuration with the airbrakes extended.
5. Keep the heavy wing as high as possible during the ground run. Change to the negative flap position after touchdown.
6. Plan the ground run to accommodate a possible ground loop towards the heavy wing.

NOTE: Check the dump valves before each flight.

Avoid dumping water for prolonged periods of asymmetric flight (for example slipping or skidding while thermalling). This reduces chances of asymmetric water load distribution.

3.11.3 Spin recovery procedure with asymmetric water ballast load

It may be possible to recover the JS-3 RES from a spin with a significant asymmetric water ballast load, provided correct recovery procedures are followed. The high rotation rate of approximately 120° per second may cause extended airbrakes to blank off the elevator. With airbrakes extended the spin attitude stabilizes with the nose approximately 20° below the horizon.

To recover from a spin towards the heavy wing, use the following procedure:

1. Apply full rudder opposite to the spin rotation.
2. Simultaneously release the elevator back pressure by moving the stick fully forward.

3. Close the airbrakes.
4. Move the flaps to the full negative position (Position 1).
5. Apply aileron into the turn.
6. Centralize the controls when the rotation stops.
7. Gently pull out of the resulting dive.

A spin entry towards the lighter wing is unlikely and recovery is normal.

WARNING: Intentional spins with water ballast are prohibited and recovery with an asymmetric water ballast load may be impossible if the incorrect recovery procedure is used.

3.11.4 Emergency landing with landing gear retracted

Emergency landings with the landing gear retracted are not recommended, because the energy absorption ability of the spring mounted landing gear is much higher than the fuselage shell. However, if an emergency landing with the landing gear retracted is inevitable, land with the flaps in the landing position L. Do not stall the aircraft more than 30 cm (1 ft) above the ground, if possible.

3.11.5 Ground loop

If a landing area is too short to stop safely before the end, a ground loop may be initiated:

1. Apply maximum wheel brake to reduce energy as much as possible.
2. Initiate a ground loop at least 50 m or 165 ft before the end of the landing area.
3. Lower the into-wind wingtip to the ground.
4. Apply the rudder towards the ground loop direction and simultaneously decrease the load on the tail wheel load by moving the control stick forward.

3.11.6 Icing

Controls may freeze up when flying in icing conditions. If ice formation is observed during flight, immediately descend below the freezing altitude level. Control surfaces should be moved continuously, and airbrakes operated frequently to avoid flight control freezing. The direct vision panel can be opened to increase visibility.

3.11.7 Emergency landing on water

During water landing tests with the landing gear retracted, it has been observed that the fuselage can submerge completely. The following procedure is recommended for an emergency landing on water:

1. Dump all ballast.
2. Make a radio call.
3. Extend the landing gear.
4. Undo the parachute harness during the downwind leg.
5. Ensure that the safety straps are tight.
6. Try to land parallel to the shore and against the wind.
7. Close the water dump valves before touchdown.
8. Touchdown with the landing gear extended and speed as low as possible.
9. At the touchdown point use the left arm to protect the face against possible canopy fracture.
10. After touchdown undo the belt harnesses.

If the aircraft has sustained no damage to the water tanks it may stay afloat for a long period. Swimming may be the only option when the airframe starts sinking.

Intentionally left blank

4 Normal operating procedures

4.1 Introduction

Section 4 provides checklists and amplified procedures for the conduct of normal operations. Normal operations associated with optional systems can be found in Section 9.

4.2 Rigging and de-rigging

4.2.1 Rigging

The JS-3 RES can be rigged by three people without rigging aids or by two people if a fuselage cradle and wing stands are available.

Preparation

1. Roll the fuselage from the trailer onto the assembly ramp (if assembly from trailer.)
2. Ensure there is adequate ground clearance to extend the main landing gear.
3. Lift the tail off the ground and attach the tail dolly, or similar to lift the tail wheel of the ground.
4. Remove the tail wheel lock pin. The tail wheel should retract.

NOTE: If the tail wheel does not retract the obstruction must be detected. It might be that the tail wheel cable has some interference. Refer to the Maintenance Manual if required.

5. Extend and lock the landing gear. Check that both wheels extend fully.
6. Remove the tail dolly and check that tail wheel is in full locked position.

Wing rigging

1. Ensure that the red rubber water drain plugs are inserted in the wing roots in front of the forward lift pin.
2. Clean and grease all pins and matching bushes, including the main pins.
3. Unlock both airbrakes using the airbrake locking wrench.
4. Set the flap handle in flap position 2 or position 3 and the control stick to the centre position.
5. Close the water valve in the cockpit.
6. Ensure that the self-aligning bushes in the main ribs of both wings are aligned correctly.
7. Ensure that the drain plugs on the root ribs of the main wing at the leading edge are installed
8. Insert the right spar end into the fuselage with the flaperon in the neutral position and the dihedral angle approximately correct.
9. Insert the left spar end into the fuselage, also with the flaperon in the neutral position and the dihedral angle as such to slide into the self-aligning bush of the other wing.
10. Insert the main pin when the wings are fully in.
11. Secure the main pin by rotating the pin into the spring-loaded lock pins.
12. Ensure that the tail is lifted off the ground with sufficient clearance for the tail wheel to extend. Extend and lock the landing gear and lower the aircraft onto the wheel. Ensure that the 18 m tip rubber water drain plugs are inserted (18 m wing tips roots on junction rib).
13. Pull the wingtip locking lever fully back and slide the wingtip beam into the main wing. Push the wingtip locking lever forward

and ensure that it locks positively by pushing the lever over-centre.

CAUTION: The flaperon sandwich can be damaged if excessive force is used and should be handled with care.

WARNING: Never grease the water drain valve, the rubber-based seal may be damaged and become detached from the valve body.

WARNING: Failure to ensure that the red rubber water drain plugs are inserted in the wing roots in front of the forward lift pin will result in water draining into the cockpit, running out through the cockpit air extractor. This may lead to asymmetrical water loadings.

Mount tailplane

1. Clean the tailplane pins and bushes.
2. Clean and lubricate the pitot-static auto-connectors. Ensure that the O-rings are serviceable.
3. Slide the tailplane onto the fin. Take care when the elevators slide into the elevator auto-coupler.
4. Ensure that the Mylar edge on the tailplane does not snag on the fin.
5. Screw the tailplane main bolt into position using the hex socket key tip of the JS rigging tool.

CAUTION: Take care not to over tighten the tailplane front attachment bolt. (Hand-tight only, maximum 1 Nm torque).

Install auxiliary items

1. Insert the 12V batteries into position in the dedicated battery compartments. Secure the 12V batteries in position with the battery retainers.
2. Check the 12V battery fuses/circuit breakers on the battery connector boxes.
3. Install the pitot-static and total energy tube and test gently for test leaks.
4. Seal the wing-fuselage junctions, wing-wingtip junctions, and the fin-tailplane junctions with tape.
5. Perform the daily inspection, including positive control check on all controls.

CAUTION: The convex shape of the canopy can act as a lens and is a fire hazard when the canopy is left open in the sun.

4.2.2 De-rigging

1. Ensure that the non-expendable tail tank is drained of water.
2. Remove auxiliary items.
3. Remove the main 12V batteries and lock the battery retainers back in position.
4. Remove the total energy tube and pitot-static tubes, as well as any temporary equipment (Logger etc.). Install the “Remove before flight”-cover in the multi-probe receptacle.
5. Remove the sealing tape on the wing-fuselage junction, wing-wing tip junctions and tailplane-fin junction.

Retracting the undercarriage

1. Lock the tail wheel in the down position by inserting the optional locking pin or ensure that the tail dolly is fitted before retracting the landing gear.
2. Roll the aircraft into the fuselage dolly. (The gear doors should be approximately 5 cm (2 inches) from the ramp end).
3. Lift the ramp until the main wheel is approximately 5 cm (2 inches) off the ground.
4. Retract the main wheel.

CAUTION: Permanent damage to the retractable tail wheel mechanism will result if the landing gear is retracted with the tail wheel on the ground.

Removing the tailplane (horizontal stabilizer)

1. Unscrew the front attachment bolt using the hex socket key tip of the JS rigging tool.
2. Slide the tailplane forward. Take care to move the tailplane forward evenly so as not to damage the elevators or the elevator auto-coupler.

3. Screw the front attachment bolt back in the fin (not applicable if a captive bolt is fitted).

Removing the wings

1. Unlock the airbrakes from the cockpit.
2. Set the flap handle in position 2 or position 3 and move the control stick to the centre position.
3. Pull the wingtip locking lever fully back and the slide wing-wingtips out of the inboard section. Secure the wingtips in the trailer.
4. Insert the tip rigging handle in the tip spar box.
5. Lift the wings at the tips until the main pin can rotate. Rotate the wing pin out of the locked position while pulling back the lock pin.
6. Remove the main pin.

CAUTION: Maintain the dihedral angle while removing the wings. The fuselage shell may be damaged if the correct angle is not maintained.

7. Pull the left wing out of the fuselage spar box and secure the wing in the trailer.
8. Pull the right wing out of the fuselage spar area and secure the wing in the trailer.
9. Lock both airbrakes, using the JS Airbrake lock tool.
10. Push the fuselage into the trailer.

NOTE: To avoid unnecessary loads on the airbrake caps, do not leave the airbrakes locked for long periods (either rigged or de-rigged). The airbrake locking tool can be used for temporarily locking the airbrakes for

maintenance or transportation, and the airbrakes should be unlocked when maintenance or transportation is complete.

CAUTION: Take care not to damage the unlocked airbrakes when using a trailer with a hinged top (e.g. Cobra, SWAN, Comet etc.). It is likely that damage will result if the airbrakes are partially or fully open when lifting the trailer top.

4.3 Daily inspections

After the aircraft has been rigged and always before the first flight of the day, the aircraft must be inspected carefully to ensure its airworthiness.

The following inspection is essential for flight safety:

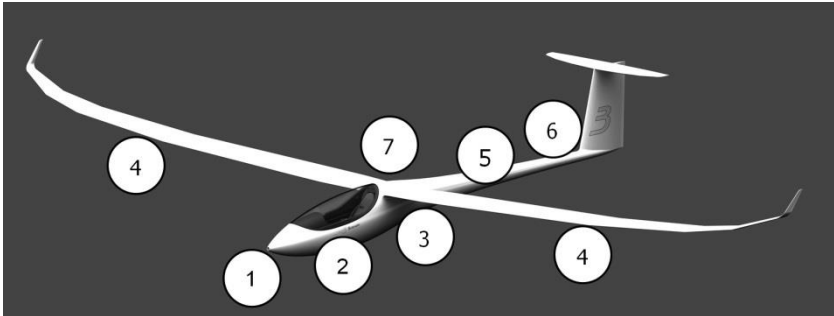

Figure 4-1

4.3.1 Forward fuselage ①

Check the functionality of the nose release hook.

4.3.2 Cockpit ②

1. Ensure that the canopy is clean.
2. Check the canopy emergency release mechanism: pull back both jettison latches slowly. A detent should be noticeable to the touch once the mechanism reaches the end of the normal opening and the emergency release is engaged. Care should be taken not to release the canopy completely without having assistance to prevent it from falling.
3. Ensure that the main pins are secured properly.

4. Ensure proper connection of the flaperon and airbrake system:
 - With the control stick in the neutral position and the flap lever in position 3, the flaperon must be flush with the trailing edge at the root rib.
 - The airbrakes must lock properly and open evenly.
5. Ensure proper operation of the rudder pedals:
 - Move the rudder pedals fully forward and backward to check the rudder cables for signs of fraying, kinks and wear, especially near the S-tube exits.
 - Perform a visual check on the rudder pedal retention nuts by checking that they are securely in place.
 - Ensure that the pedals lock positively in the desired setting under load.
6. Ensure proper operation of the water system (main and tail tank valves).
7. Ensure that charged 12V batteries are correctly installed and connected.
8. Ensure that the oxygen bottle is properly secured.
9. Ensure that the cockpit is clean, and all foreign matter is removed.
10. Ensure proper condition and operation of the safety belts, especially where they pass through the seat back.

4.3.3 Landing gear ③

1. Visually inspect the mechanism and locks.
2. Check the condition of the shock absorbing rubbers.
3. Check the tyre pressures:
 - Main wheel - 15 m: 2.5 bar (36 psi)
 - Main wheel - 18 m: 3.5 bar (51 psi)
 - Tail wheel: 2.5 bar (36 psi)
4. Check the tyre slip mark position and tyre condition.
5. Check the condition of the wheel doors hinges and closing springs or bungee cords.
6. Check that the CG hook manual and automatic operation works properly. Accumulated dirt or mud may lead to improper functioning of the release hook.
7. Check that the water drain orifice behind the landing gear box is clear.

4.3.4 Wings ④

1. General condition: Check for evidence of damage to the surface finish or structural damage, pressure marks and cracks.
2. Check that the water drain orifices at the wing root and tip are clear.
3. Check the airbrakes for functioning and locking. Check for water or foreign objects in the airbrake boxes.
4. Check that the outer wing panel is properly locked without play.
5. Check that the flaperons move freely with no hinge play. Perform a positive control check on the inboard and outboard flap.

6. Check that the wing tip wheels are in good condition: The clearance between the flap trailing edge and the ground in positive flap with maximum aileron deflection must be at least 10 mm. Check that the wheels are attached positively to the wing.
7. Check that the control surface gap seals are installed and properly adhered to the wing recesses.
8. Check that the NACA ducts on the lower surface of the flaperons are clear.
9. If the bug wiper system is installed, perform the checks given in Section 7.12.3.
10. If flying with water ballast:
 - Check before filling if all the rubber seals on the dump valves are in position and that all valves are operating correctly.
 - Check the dump rate of the main tanks with the filler caps installed. Ensure that the dump rates of the left and right wings are equal and that the dump rate is faster than that of the tail tank.

4.3.5 Fuselage ⑤

1. General condition: Check for evidence of damage to the surface finish or structural damage, pressure marks and cracks.
2. Check that the static pressure ports on the fuselage boom are unobstructed.
3. Check that the tail wheel is sufficiently inflated.
4. Check that the water drain orifice in front of the tail wheel is not obstructed.

4.3.6 Tail section ⑥

1. General condition: Check for evidence of damage to the surface finish or structural damage, pressure marks and cracks.

2. Check that the total energy and pitot-static probe receptacles are clear. Drain all possible water from the receptacle (if the probe was left in position during rain) by removing the tailplane and rotating it.
3. Ensure that the total energy and pitot-static probes are installed correctly and pushed all the way in. The pitot-static probe is positioned on the right-hand tailplane tip. Check instrument functionality by carefully blowing on the multi-probe's pitot-, static and total energy ports.
4. Check that the expendable tail tank has no water before filling, by blowing into the filling port with the dump valve in the open position and the vent holes blocked.
5. Check the vertical tail tank valve operation. Check that the dump rate of the tail tank exceeds 1 litre per minute.
6. Check that the tank vent holes on the left-hand side of the fin are unobstructed.
7. Check that the amount of water in the vertical tail fin water ballast tank is correct in relation to the wing water ballast and cockpit load.
8. Check that the horizontal stabilizer is properly installed without play.
9. Check that the control surface gap seals are installed and properly adhered to the stabilizer and fin recesses.

CAUTION: Blowing into the pitot, static and total energy ports of the pneumatic probes may cause permanent damage to connected cockpit instruments if performed incorrectly.

4.3.7 Retractable Electric System ⑦

Inspect the RES in accordance with JS-MD 3 RES Flight Manual Supplement.

4.4 Pre-flight check

- | | |
|--------------------------|---|
| Daily inspection | - Performed |
| Control systems | - Functional check, positively connected, free movement and no play |
| Expendable tail tank | - Valve opening positively checked |
| Non-expendable tail tank | - Ensure empty or correctly loaded for CG range |
| Water ballast system | - Check operation and proper sealing of valves and vents unobstructed
(Ensure that there are no leaks from the root rib drain plugs and on the 18m tips at the junction drain plugs after filling the aircraft with ballast) |
| Mass and balance | - Trim weight, water ballast (tail and wing tanks), minimum and maximum cockpit load within calculated limits |
| Total energy tube | - Fitted and connection properly sealed, indication ok |
| Altimeter | - Set correctly (QNH / QFE / QNE) |
| Radio | - Set to airfield frequency, check operation |
| Other instrumentation | - Checked, normally indicating zero |
| Backrest | - Adjusted |
| Rudder pedals | - Adjusted and locks positively in all settings |
| Documentation | - Complete and valid |
| Landing gear | - Locked with no play |

Pre Flight Checklist

Main wing boltInstalled and secured
 Horizontal tail bolt.....Installed
 Total energy tube (LH side of tailplane).....Installed
 Pitot/Static tube (RH side of tailplane).....Installed
 Tail wheel lock pin Removed
 ControlsFreedom of movement
 AirbrakesOperation OK, fasteners are secured
 Water tank valvesoperation OK
 Tail tank outlet.....Clear & dumps with main tanks
 Weight & balanceVerify within limits
 Non-expendable tank.....Correct water quantity
 Tire pressures.....Check
 Wheel brake pressureCheck
 Seat back & rudder pedals.....Adjusted
 Instruments & avionics.....Serviceable
 Batteries.....Check voltage & connection
 CG loading.....Set nose/tail ballast as required

Pre Take-Off Checks

Cockpit controls.....Reachable
 Flight controls.....Checked
 Loading within permissible CG range.....Checked
 Parachute & safety harness.....Fastened
 Flight instruments.....Set
 Trim.....Set
 Flaps 4.....Select
 (For improved roll control select flap 1 during initial ground run)
 Canopy.....Closed & latched
 Airbraked.....Closed & locked
 Tail dolly & tail wheel lock.....Removed
 Landing gear handle.....Locked position
 Wind direction.....Checked

Winch/Aerotow: Ensure winch operator or tug pilot is familiar with speed requirements and limitations.

Self Launch: Refer to section H. Ensure both batteries are connected to HV bus and are sufficiently charged.

Figure 4-2 Pre-flight and pre take-off check placard

4.5 Normal procedures and recommended speeds

4.5.1 Winch launch procedures

Winch launching is performed using the CG hook in front of the main wheel.

With a slow-accelerating winch, good aileron control is achieved using flap 3. With a gentle to strong headwind flap 4 may be used from the start.

Allow the aircraft to get airborne in the 2-point position (main wheel and tail wheel just touching). As the speed builds up, gently rotate into the full climbing attitude. Change to flap setting 4 when the aircraft is established in the full climbing attitude.

Winch launch speed table	Airspeed km/h / (kts)
Recommended winch launch airspeed (No water ballast)	130 km/h (70.2 kts)
Recommended winch launch airspeed (MTOM)	140 km/h (75.6 kts)
Minimum safe winch launch speed without water ballast	115 km/h (62.1 kts)
Minimum safe winch launch speed with water ballast	125 km/h (67.5 kts)
Maximum winch launch speed (V_w)	150 km/h (80.9 kts)

Table 4-1 Winch launch speed table

To release, pull the yellow release handle all the way.

Winch launches executed at wing loads exceeding 55kg/m² (11.2 lbs/ft²) are not recommended, as many winches are not capable of achieving the high speed required for a safe winch launch.

Recommended loads for winch launches	15 m	18 m
Recommended maximum take-off weight for winch launching	475 kg (1047 lbs)	550 kg (1212 lbs)
Recommended most aft CG position	355 mm (14 in)	355 mm (14 in)

Table 4-2 Winch launch recommended maximum loads

WARNING: With the CG in the aft position and fast acceleration, the aircraft will automatically rotate into the climb.

WARNING: Downwind winch launches jeopardise the safety of the launch significantly and should be avoided.

WARNING: Winch launch with water ballast should only be attempted with a powerful winch and into the wind.

WARNING: Winch launches with wing loads exceeding 55kg/m² should be done with extreme care, as a high launch speed is required to perform the launch safely.

WARNING: Release immediately if the wings cannot be kept level during the ground run.

WARNING: Retracting the landing gear during the winch launch is not permitted.

4.5.2 Aerotow assisted self-launch procedure

Refer to Section 6.2 in the JS-MD 3 RES Flight Manual Supplement.

4.5.3 Engine operation procedures

4.5.3.1 Engine start, run-up, taxi procedures

Refer to section 2.5.2 in the JS-MD 3 RES Flight Manual Supplement.

4.5.3.2 Self-launch

Refer to section 2.5.3 in the JS-MD 3 RES Flight Manual Supplement.

4.5.4 Flight

The JS-3 RES offers exceptionally good flying characteristics, handling and manoeuvrability.

4.5.4.1 Thermalling

The optimum flap setting for thermalling is position 4 or 5.

Flap setting 4 is the normal thermalling flap setting. The optimum thermal speed at maximum load is 110 to 115 km/h (59.4 to 62.1 kts).

When the thermals are very rough it is recommended to fly slightly faster (120 km/h / 64.8 kts).

Flap setting 5 provides the best results in smooth thermals where minimal centring is required. At maximum weight the best speed to fly is 108 to 110 km/h (58.3 to 59.4 kts) in this flap setting.

4.5.4.2 Inter thermal cruise

To optimise the glide performance, it is important to select the proper flap according to the weight and cruise speed. The flaps modify the camber of the airfoil, maintaining laminar flow over a wide range of lift coefficients. For every speed and weight combination there is an optimum flap setting for maximising the glide angle.

The following table gives the optimum flap setting as a function of speed and weight.

Flap settings		4	3	2	1
Deflection		+13.5°	+5°	0°	-3°
Configuration	With no water ballast	90 - 110 km/h 48.6 – 59.4 kts	110 - 120 km/h 59.4 – 64.8 kts	120 - 180 km/h 64.8 - 97.2 kts	180 km/h - V_{NE} 97.2 kts - V_{NE}
	With max water ballast	105 - 125 km/h 56.7 – 67.5 kts	125 - 140 km/h 67.5 – 75.6 kts	140 - 200 km/h 75.6 – 108.0 kts	200 - V_{NE} km/h 108.0 kts - V_{NE}

Table 4-4

CAUTION: Observe the airspeed limits versus altitude (Figure 4-5) to avoid exceeding V_{NE} and V_{FE} .

4.5.4.3 In-flight motor start procedures

Refer to section 5.3 in the JS-MD 3 RES Flight Manual Supplement.

4.5.4.4 Motor operation in flight

Refer to section 5 JS-MD 3 RES Flight Manual Supplement.

4.5.4.5 In-flight motor stop procedure

Refer to section 5.4 in the JS-MD 3 RES Flight Manual Supplement.

4.5.4.6 Lightning

The JS-3 RES is not approved for flight where lightning strikes may occur.

WARNING: Flights in conditions conducive to lightning strikes must be avoided.

4.5.5 Approach

The circuit can be flown with the flaps set to setting 3 to 5 (+5° to +16.7°). On final approach for landing the flaps can be changed to position L (+20°) for a shorter landing at a lower touchdown speed. Due to high aerodynamic forces, the flaps may not be extended to setting L above 160 km/h (or 86 kts).

Water ballast should be dumped prior to landing. Refer to Section 3.11.2 for asymmetric loads.

Ensure that the landing gear is down and locked and verified as such before commencing final approach. The landing gear is lowered when the cockpit handle is moved to the forward position.

Landing with the pylon extended is permitted but not recommended.

CAUTION: With the pylon extended and the RES in 0% power setting, the sink rate of the glider increased by approximately 0.5m/s. If the propeller is wind milling (Pylon extended, but system switched off) the sink rate is further increased and the noise level is slightly more than usual.

Table 4-5 gives the recommended airspeeds for the approach:

Minimum Recommended Approach Speeds: (Various Approach Types)	Load configuration	
	Without water ballast	Max. Take-off Mass
Calm conditions	110 km/h 59.4 kts	125 km/h 67.5 kts
Approach in rain	120 km/h 64.8 kts	135 km/h 72.9 kts
Strong crosswind, flap setting 3	120 km/h 64.8 kts	135 km/h 72.9 kts

Table 4-5

At maximum take-off mass with the airbrakes fully extended and at 117 km/h (63.2 kts) the approach angle is approximately 1:6 (in calm conditions). Any increase in airspeed increases the approach angle significantly and at V_{NE} without water ballast the descent angle is approximately 45°.

CAUTION: When on final approach, do not change to a more negative flap setting (for example, from setting L to setting 4) without sufficient airspeed as the resulting loss of lift will cause a significant loss in altitude.

CAUTION: Always lower and ensure that the landing gear is locked, especially in the case of an emergency landing.

NOTE: Side-slipping the JS-3 RES on final approach is not recommended as it is an inefficient method to increase the sink rate. However, the aircraft can be side-slipped up to a speed of 203 km/h (109.6 kts). Partial water ballast has no noticeable effect on the flying characteristics during a sideslip. Airspeed indication may under-read at yaw angles exceeding 20°.

WARNING: When executing a sideslip exceeding an angle of 20° , the control force gradient may become negative i.e. the rudder will be aerodynamically pushed against the rudder stop. This can be corrected by applying opposite rudder. Refer to Section 3.7 for the excessive sideslip recovery procedure.

NOTE: Landing in flap setting 2 or setting 1 is strongly discouraged due to the increased stall speeds.

NOTE: In the landing configuration with aft CG the maximum trim speed is $0.84 V_{FE}$.

4.5.6 Landing

The correct attitude for landing is the two-point attitude with the main wheel and tail wheel making contact with the ground simultaneously.

The hydraulic wheel brake is activated by squeezing the trigger on the control stick. Ensure that the wheel brake is not applied before touchdown.



Figure 4-3 Wheel brake placard

After touchdown the wheel brake can be activated. It is recommended to select negative flaps (Setting 1) after touchdown. This reduces the risk of nose-over when braking hard, reduces the chances of damaging the flaperon trailing edges on uneven surfaces and improves aileron control at low speeds.

Whilst slowing down, and it is no longer possible to keep the wings level, centralise the ailerons and brake positively to stop completely.

This minimises wear on the tip skid/wheel and reduces the risk of damaging the flaperons.

Safe landing in cross-winds up to 30 km/h (16.2 kts) is possible due to the polyhedral wing shape allowing high bank angles during touchdown:

1. Use flap setting 4 for moderate crosswinds and setting 3 for strong crosswinds (exceeding 25 km/h or 13.5 kts).
2. Align the aircraft nose with the runway centreline using the rudder.
3. Lower the into-wind wing sufficiently to overcome drift.
4. Keep the into-wind wing lowered until coming to a complete stop.
5. Change to flap setting 1 only after touchdown when slowing down.

NOTE: It is not recommended to apply the park brake if fitted. Effective braking force is lost if the brake system is pressurised for an extended period of time.

4.5.7 Flying with water ballast

The water ballast system allows the mass of the aircraft to be increased to achieve higher wing loads.

Table 4-6 gives the tank capacity for the JS-3 RES.

Water Ballast Capacity (Litres)	15 m	18 m
Main inboard wings (see note)	66 x 2 litres	
Wing tips	0 litres	17 x 2 litres
Expendable tank capacity	5.8 litres	
Non-expendable tank(s)	8.9 litres	
Total expendable water capacity	137.8 litres	171.8 litres

Table 4-6

NOTE: Capacities provided are estimates only. Due to manufacturing tolerances, deviations can be expected.

NOTE: The JS3 main wings with a water capacity of 78 l per wing is also a customer option to be used with the RES configuration.

Figure 4-4 indicates the expendable water quantity required to balance the water in the main inboard wing tanks.

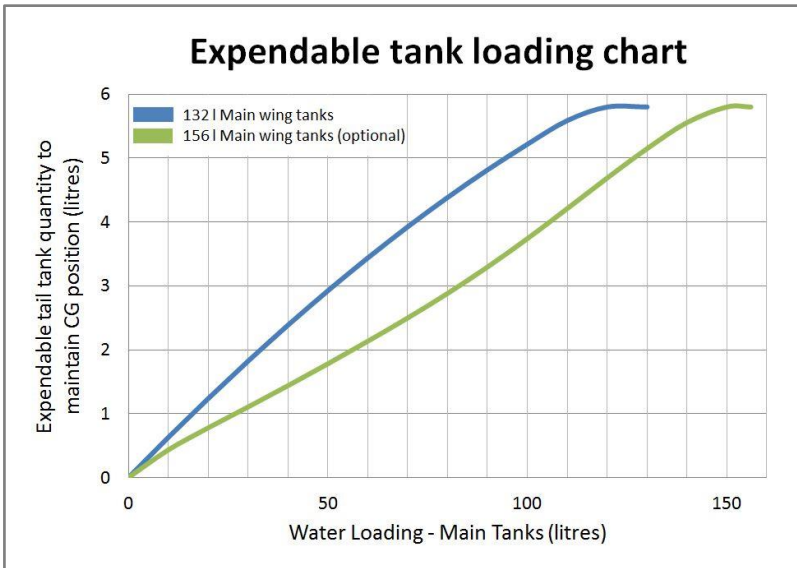

Figure 4-4

- NOTE:** As a conservative approximation, add 1 litre of water in the expendable tail tank for every 20 litres of water in the main inboard wing tanks (or 30 litres for the optional 156 l main inboard wing tanks).
- WARNING:** The tail tank should always be filled based on the CG calculation as described in Section 6. Under no circumstances is it permitted to fly with the CG aft of the rear limit.
- CAUTION:** The filler caps must always be locked finger tight only. Excessive torque may damage the edges of the filler caps.

4.5.7.1 Filling procedure

1. Determine the quantity of water ballast to be carried. The quantity of water ballast in the tail is calculated using the graph in Figure 4-4.
2. Determine the quantity of water to be loaded in each tank. In the 18 m configuration the tips must be filled if water is carried in the main tanks. If the tanks are partially loaded, water must be loaded in the following sequence:
 - 18 m tips (if fitted)
 - Main wing tanks
3. Open the dump valve in the cockpit and ensure that the expendable tail tank is empty by following the procedure given in the daily inspection check list.
4. Close the dump valve in the cockpit.
5. Fill the 18 m tips (if fitted). Filling can be done via the filling caps located on the top surface near the winglet.
6. Fill the main tanks via the filler caps on the top surface.
7. The expendable tail tank can be filled using the bottom filling port on the left-hand side of the fin. Ensure that the quantity water in the expendable tank is in relation to the quantity of water in the main tanks.
8. Fill the non-expendable tail tank as follows:
 - Calculate the quantity of ballast for the non-expendable tank using the calculations explained in Section 6.
 - Seal the dump holes (3 mm holes on left hand side of fin) with a sealing vinyl sticker up to the required level.
 - Add water ballast using the filling port(s) on the left-hand side of the fin. Refer to section 7.8.4.2 for details.

4.5.7.2 Dumping procedure

1. Open the valves by shifting the dump valve lever forward and down. The combined dump rate of the main tanks is approximately 50 litres per minute. The dump rate will slow down when approximately 20 % of water is left.
2. Visually check if water is dumping from both wings (the water trails can be seen below the wings near the fuselage, and at the tips in the 18 m configuration). In the event that any of the valves are not dumping, the valves must be closed immediately to prevent an asymmetric water ballast load condition.
3. To dump the ballast only partially, the inboard wings must be dumped first. This is achieved by moving the dump valve lever to the centre position.
4. If progressively increased aileron deflection is required to maintain bank angle while dumping water, the water is probably dumping unevenly. Refer to Section 3.11.2 for details on asymmetrical flight procedures.
5. If more nose-down trim is required after dumping water ballast, it is likely that the expendable tail water ballast has not been dumped. In this case avoid flying at speeds near the stall.
6. Allow sufficient time to completely dump all water before landing. (Approximately five minutes is required.)

NOTE: Increase tyre pressure up to 3.5 bar (or 50.8 psi) when flying fully loaded in the 18 m configuration.

CAUTION: Use clean water without any additives to avoid damage to the inner water ballast structures and rubber seals.

- WARNING:** Residual air may create undue pressure during flights with partially loaded or empty tanks. Always check to ensure that the vent holes of the fin tanks are always open and that the pressure relief valve in the main tank is functional.
- WARNING:** Never apply more than 0.1 bar of water pressure (filling funnel height no more than one metre above the wing) because of possible damage to the structure.
- WARNING:** Ensure that both wing tanks are filled with equal amounts of water to prevent wing dropping on take-off.
- WARNING:** Check for the correct dumping sequence. The tail tank must finish dumping before the main wing tanks to ensure safe shifting of the CG.
- WARNING:** The wing tips must be filled with water ballast if the main tanks are filled (even partially filled).
- WARNING:** No tail ballast compensation is required for water loaded in the 18 m tips. The CG moves approximately 6 mm rearwards when filling the 18 m tips.
- WARNING:** Use of water ballast is limited to non-freezing flight conditions. Do not use water ballast for prolonged flights below 0 °C (32 °F).
- WARNING:** Do not use any lubricant (grease or petroleum jelly) or wax to seal any water valves that do not seal properly. Most lubricants affect the rubber seal and may result in the seal detaching from the valve unit.

4.5.8 High altitude flight

At higher altitudes the air speed indicator will indicate values lower than the true airspeed due to the lower air density. This does not influence loads on the structure, but it does mean that the colour markings on the air speed indicator are not correct at high density altitudes. As flutter depends upon true airspeed, the maximum allowable airspeed must be reduced at high altitudes. Figure 4-5 gives the V_{NE} as a function of altitude for both the 15 m and 18 m configurations.

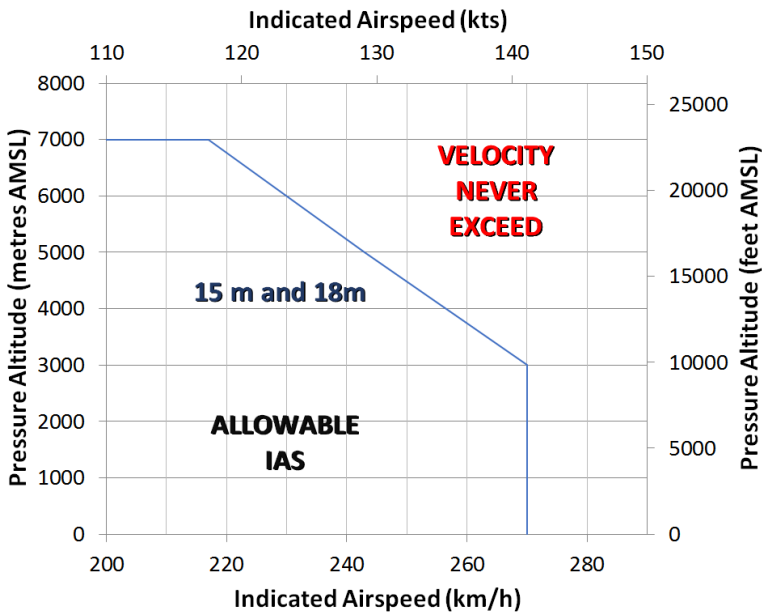

Figure 4-5

The fixed placard is illustrated in Figure 4-6. The equivalent limitations are provided in the Placard Booklet.

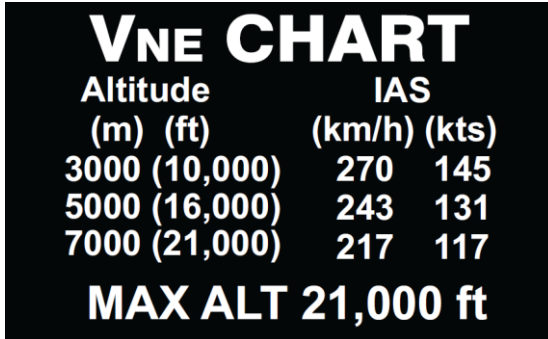

Figure 4-6

WARNING: The aircraft is not approved for flights above 7000 m (21000 ft) AMSL.

CAUTION: At higher altitudes the true airspeed (TAS) is higher than the indicated airspeed (IAS). Reduce the indicated airspeed to compensate for the effect of high altitude.

4.5.9 Flight in rain

When flying in rain a decrease in glide performance is expected. The airfoil is specially designed not to have any loss in lift when contaminated and the stall speed is relatively unaffected by rain and bugs. However, it is recommended to increase the landing speed by at least 10 km/h (or 5.4 kts) to compensate for turbulence and descending air often associated with rain. The direct vision panel can be opened to increase visibility.

See Section 4.5.5 for the recommended approach speeds associated with flight in rain.

The RES is certified for operation in rainy conditions with the following performance limitations:

- Light to medium rain only
- No more than MCP
- RPM limitation: Refer to the JS-MD 3 RES Flight Manual Supplement

After each flight in the rain, ensure that the prop did not sustain any damage (visual inspection) and ensure that there is no standing water in the RES compartment. Before charging or connecting the batteries, ensure that the connectors are free from water.

4.5.10 Using bug wipers in flight

The operation of the bug wipers in flight depends on the winder system installed. Refer to the instructions of the winder manufacturer for details on the operation. The following basic rules apply:

1. Ensure that sufficient battery capacity is available to perform the cleaning operation and select the correct 12V battery source for the winders.
2. Cleaning can be performed in level flight or during climbing, as long as the airspeed is maintained between 100 km/h and 120 km/h (54.0 kts and 64.7 kts). The aircraft should be flown without excessive slipping or skidding.
3. If the wings are allowed to get too contaminated the wiper might get stuck in an area. The application of Teflon-based polish before flight will assist in preventing this problem. It may be attempted to run the wiper over the contaminated area (if possible) until the surface is smooth.

CAUTION: Do not operate the bug wipers in very turbulent conditions or outside of the tested speed range. The bug wiper may be thrown off the wing.

CAUTION: Bug wiper operation in uncoordinated flight attitude may result in the wiper becoming unstable. Ensure that the yaw string is straight, especially when wiping the inner wing whilst turning.

4.5.11 Aerobatics

The entry speeds and recommended maximum G-loads for approved aerobatic manoeuvres are given in Table 4-7 below.

Aerobatic entry speed	Flap Setting	Entry speed	G-load
Lazy Eight	3	180 km/h (97.2 kts)	3
Chandelle	3	150 km/h (81.0 kts)	2
Steep turn	3	150 km/h (81.0 kts)	3
Positive loop	3	200 km/h (108.0 kts)	3.5
Stall turns	3	200 km/h (108.0 kts)	3

Table 4-7 Aerobatic entry speed

4.5.12 Flight over built-up areas

Use of the RES, if fitted, over built-up areas is not recommended.

Intentionally left blank

5 Performance

5.1 Introduction

Section 5 provides approved data for airspeed calibration, stall speeds, take-off performance and other non-approved information.

The data in the charts has been computed from actual flight tests with the aircraft in good conditions and using average piloting techniques.

5.2 Approved data

5.2.1 Airspeed indicator calibration

During airspeed calibration tests the airspeed indicating system was found to be accurate within 2 % over the whole range from V_{S0} to V_{NE} . Figure 5-1 gives the airspeed correction chart.

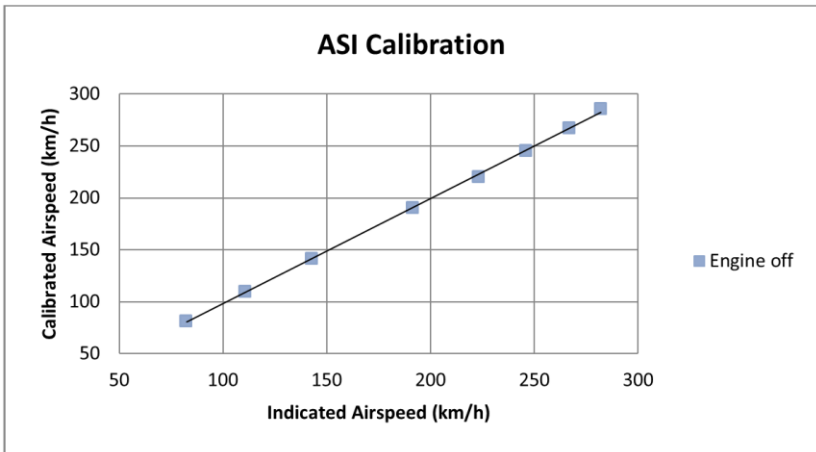

Figure 5-1: ASI calibration chart

5.2.2 Stall speeds

The stall speeds (IAS) for the 15 m and 18 m configurations of the JS-3 RES are given in Table 5-1 and Table 5-2.

Table 5-1 gives the stall speeds for the JS-3 RES (15 m configuration) with the airbrakes retracted and CG in the foremost position:

15 m configuration (forward CG)

Gross weight	415 kg / 915 lbs		525 kg / 1157 lbs	
Flap setting	Minimum achievable speed (IAS), CG fwd.		Minimum achievable speed (IAS), CG fwd.	
L (20°)	78 km/h	42.2 kts	86 km/h	46.5 kts
5 (16.6°)	79 km/h	42.7 kts	88 km/h	47.6 kts
3 (5°)	87 km/h	47.0 kts	95 km/h	51.3 kts
1 (-3°)	91 km/h	49.2 kts	98 km/h	53.0 kts

Table 5-1

Table 5-2 gives the stall speed with the airbrakes retracted and CG in the foremost position in the 18 m configuration:

18 m configuration (forward CG)

Gross weight	430 kg / 948 lbs		600 kg / 1322 lbs	
Flap setting	Minimum achievable speed (IAS), CG fwd.		Minimum achievable speed (IAS), CG fwd.	
L (20°)	74 km/h	40.0 kts	88 km/h	47.6 kts
5 (16.6°)	74 km/h	40.0 kts	83 km/h	44.9 kts
3 (5°)	81 km/h	43.8 kts	89 km/h	48.1 kts
1 (-3°)	89 km/h	48.1 kts	97 km/h	52.4 kts

Table 5-2

With the CG in the forward position the elevator is not able to produce a sufficiently high angle of attack to completely stall the wings with positive flap settings. In this case, the stall speeds are defined by the minimum achievable speed for the specific flap setting.

The stall speed in all flap settings is increased by approximately 5 km/h with the airbrakes extended. The landing gear position has no measurable influence on the stall speeds.

5.2.3 Take-off performance

Refer to section 7 in the JS-MD 3 RES Flight Manual Supplement.

5.2.4 Additional information

5.2.4.1 Turbulators

On the lower surface of the flaperons there is a line of blow holes supplying air by NACA ducts. It is necessary to keep these holes and ducts clean for optimum performance. The blow holes force the boundary layer transition from laminar flow to turbulent flow in flap setting 1 and 2. If the boundary layer control is not working properly, a whistling sound can be heard when changing to flap setting 1 and 2.

WARNING: Turbulator tape is fitted to the tailplane and rudder and is essential for both the performance and control of the aircraft. Flight without tailplane turbulators is not allowed as it might result in a reduction in pitch authority. See the JS-MD 3 RES Aircraft Maintenance Manual for the correct location of the turbulator tape.

5.3 Non-approved information

5.3.1 Demonstrated crosswind performance

The JS-3 RES has very good crosswind handling characteristics due to its polyhedral wing shape allowing high bank angles during touchdown.

The maximum demonstrated crosswind components are:

- During take-off: 25 km/h (13.5 kts)
- During landing: 30 km/h (16.2 kts)

NOTE: See Section 4 on Approach and Landing for more information on landing in crosswinds.

5.3.2 Noise data

Not applicable to the pure sailplane or RES aircraft.

5.3.3 Flight polar

Figure 5-2 illustrates the calculated polar for the JS-3 RES in the 15 m and 18 m configurations for two wing load cases:

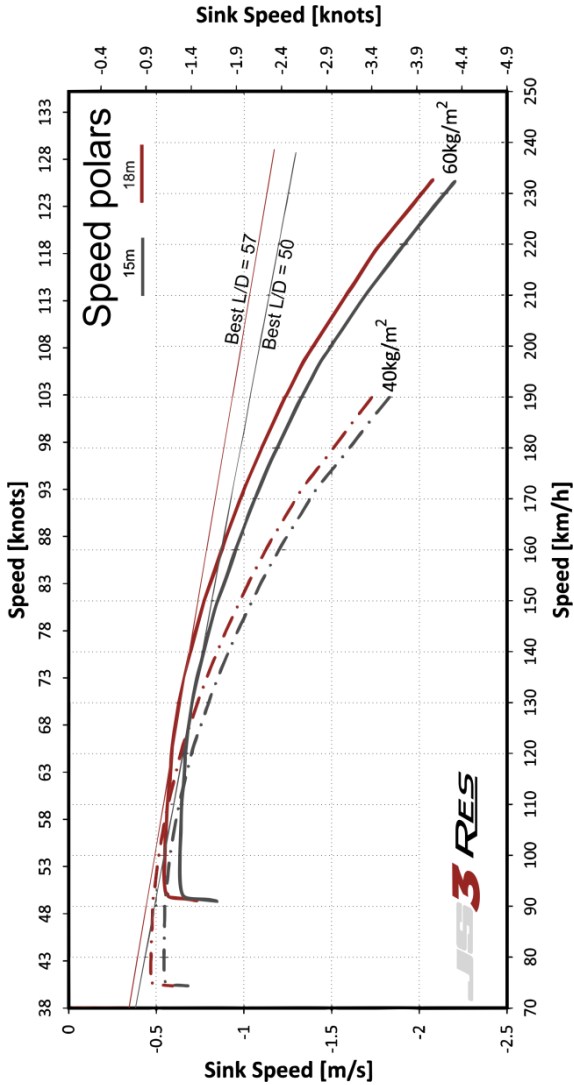

Figure 5-2

Table 5-3 gives the coefficients of the second-degree polynomial approximation of the JS-3 RES' polar curve in the 15 m and 18 m configurations for a specific reference mass.

Configuration		15m		18m	
Reference mass		450 kg	992 lbs	500 kg	1102 lbs
Polar coefficients	a	0.9847		0.9233	
	b	-1.8498		-1.6595	
	c	1.4745		1.2658	

Table 5-3

NOTE: The calculated flight polar can be represented by a second-degree polynomial function. Various flight computers use these functions and accompanied coefficients as approximations where glider performance prediction is required, e.g. to calculate speed to fly and final glide calculations.

6 Weight and balance

6.1 Introduction

Section 6 contains the payload range for the JS-3 RES aircraft within which it can be operated safely.

The procedures for weighing and establishing the permitted payload range is given in JS-MD 3 Aircraft Maintenance Manual, including:

- Weighing procedures
- CG calculation formulas
- Calculation of minimum and maximum cockpit loads

6.2 Weight and balance record

The weight and balance record summarizes the results of weight and balance calculations and gives the maximum and minimum allowable pilot weights for the aircraft.

The calculated minimum and maximum cockpit loads (as entered on the cockpit placard) must correlate with the values in the mass and balance report and the latest entry in the logbook weight and balance section.

NOTE: The data presented on the weight and balance record (Table 6-1) is only valid for the aircraft whose serial number is entered on the form.

Weight and Balance Record Sheet: 15 & 18 m configuration

Date	Wingspan	Empty weight (M _{EMPTY})	Empty CG position (X _{CG})	Permitted pilot weights				S/N:
				Non-Expendable fin tank(s) empty		Non-Expendable fin tank(s) full		Approval Name / Signature
				Min	Max	Min	Max	
	15							
	18							
	15							
	18							
	15							
	18							
	15							
	18							
	15							
	18							
	15							
	18							
	15							
	18							

Table 6-1

CAUTION: When RES HV batteries, weighing 24.85 kg each, are installed, the permitted minimum cockpit load must be increased with ~11.6 kg (25.6 lbs) per battery.

Weight and Balance Record Sheet: 15 & 18 m configuration

Date	Wingspan	Empty weight (M _{EMPTY})	Empty CG position (X _{CG})	Permitted pilot weights				S/N:
				Non-Expendable fin tank(s) empty		Non-Expendable fin tank(s) full		Approval Name / Signature
				Min	Max	Min	Max	
	15							
	18							
	15							
	18							
	15							
	18							
	15							
	18							
	15							
	18							
	15							
	18							
	15							
	18							

For the calculation of the permitted maximum and minimum pilot weight refer to formulas given in the JS-MD 3 RES Aircraft Maintenance Manual Chapter 8.

6.3 Permitted payload-range and CG envelope

The JS-3 RES CG envelope is based on the allowable flying mass and CG ranges given in Section 2.5 and Section 2.6.

Care must be taken that the CG stays within the allowable limits. The following loads have an effect on the CG position:

- Pilot
- Cockpit ballast (removable)
- RES HV Batteries
- Water ballast: Main tank (and tip tanks in 18 m configuration)
- Water ballast: Expendable tail tank
- Non-expendable tail tank
- Baggage
- O₂ bottle
- Fin ballast

Adjustment possibilities, such as cockpit ballast, lead tail ballast and water in the non-expendable tail tank (top fin tank), is available to help the pilot achieve the desired CG position.

The expendable water tank in the fin (bottom fin tank) is used to offset the CG change due to the water ballast in the main wing tanks. No change in the set CG is expected during dumping when this tank is correctly loaded.

Figure 6-1 and Table 6-2 give the maximum mass and the moment arms of the various variable loads for the JS-3 RES. The moment arms are measured from the datum with the following sign convention:

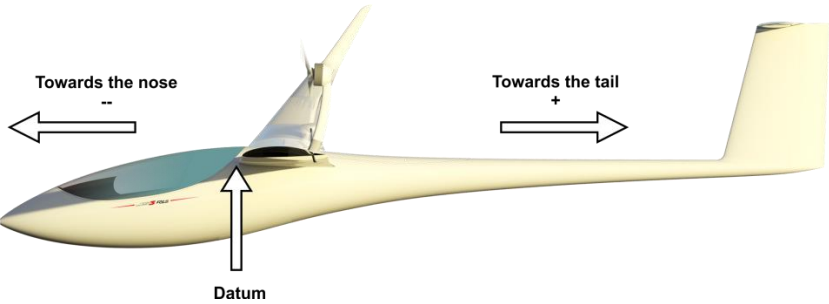

Figure 6-1

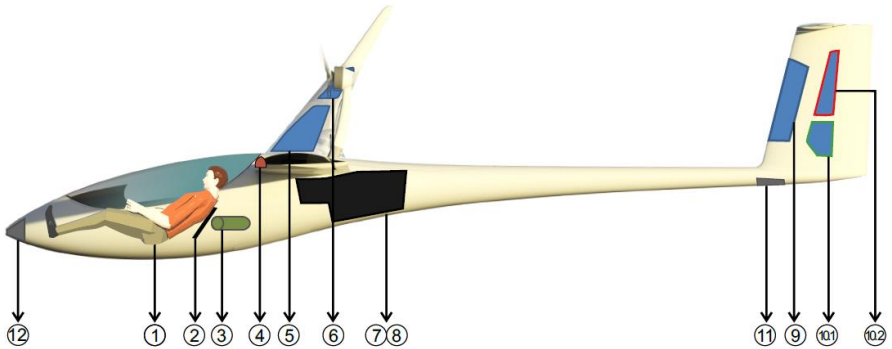

Figure 6-2

#	Moment	Load point	Max Mass		Moment arm	
			kg	lbs	mm	inch
1	M _{Pilot}	Pilot (with parachute)	115	253.5	-645	-25.4
2	M _{Cockpit}	Cockpit ballast (removable)	20	44.0	-450	-17.7
3	M _{O2}	O2 bottle AL248	2.0	4.4	0	0
4	M _{Bag}	Baggage compartment	1.0	2.2	150	5.9
5	M _{WingM}	Water ballast – main _{132l}	132	291.0	212	8.3
		Water ballast – main _{156l}	156	343.9	247	9.7
6	M _{WingT}	Water ballast – tip (18 m)	34	74.9	480	18.9
7	M _{Batt1}	RES HV Battery 1	24.9	54.9	879	34.6
8	M _{Batt2}	RES HV Battery 2	24.9	54.9	879	34.6
9	M _{Tail1}	Expendable tail tank	5.8	12.7	4285	168.7
10.1	M _{Tail2}	Non-expendable tail tank (top)	5.0	11.0	4574	180.1
10.2	M _{Tail3}	Non-expendable tail tank (bottom)	3.9	8.5	4510	180.0
11	M _{Tail3}	Tail lead ballast (permanent)	5.6	12.3	4121	162.2
12	M _{NoseW}	Nose weights in front of pedals	12.0	26.5	-1782	-70.2

Table 6-2

NOTE:

The moment arm of the main water ballast is a conservative approximation and changes as the tanks are filled from 150 mm to 212 mm for the 132 l tanks, and 200 mm to 247 mm for the optional larger 156 l tanks. See Figure 6-3.

Main Tanks Moment Arm vs Loading

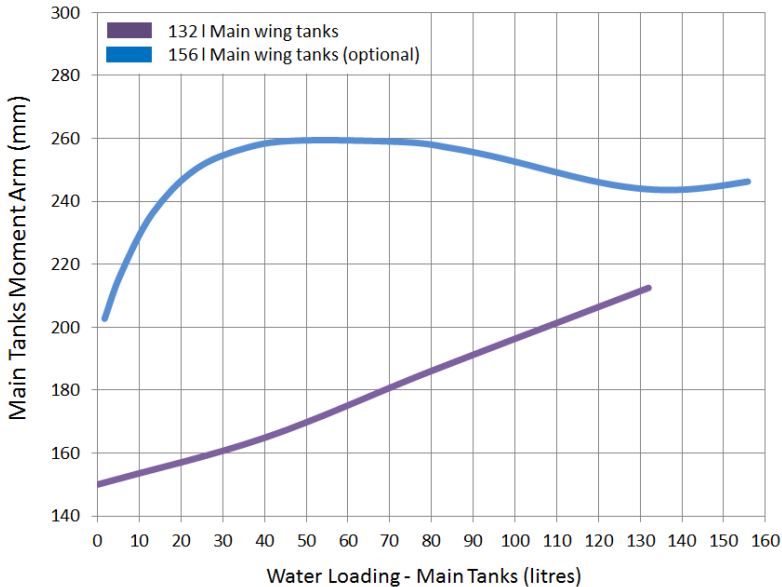

Figure 6-3 Main Tanks Moment arm vs Loading

To determine if a selected load falls within the CG envelope, as illustrated in Figure 6-4, the following procedure can be used:

1. List all the loads in table format as illustrated in Table 6-2 (Include the mass and CG arm of the empty aircraft as obtained in the mass and balance report).
2. Calculate the moments for each load, using the formula:

$$\textbf{Moment} = \textbf{Mass} \times \textbf{Moment arm}$$
3. Add the mass of the applicable loads
4. Add the moments of the applicable loads
5. Plot the mass against the moment on the JS-3 RES Envelope diagram (Figure 6-3).

6. The Flying CG can also be calculated using the formula

$$\text{Flying CG position} = (\text{Total of Moments}) / (\text{Total Mass})$$

Example:

Determine if the following loads fall within the allowable envelope:

- Empty aircraft: 300 kg, CG position 470 mm
- Pilot with parachute weighs 90 kg
- Both the main tanks (132l) and expendable tail tanks filled to reach MTOW in 15m configuration.
- The non-expendable tail tank filled with 8.9 litres of water
- An O₂ bottle of 2 kg fitted.

This example is given in metric units only.

#	Load point	Mass kg	Arm mm	Moment (kg.m) Mass x Arm/1000
	Empty aircraft	300	470	141.0
1	Pilot and parachute	90	-645	-58.1
5	Water ballast – main	118	205	24.2
9	Expendable tail tank	5.8	4285	24.9
10.1	Non-expendable tail tank (top)	5	4574	22.9
10.2	Non-expendable tail tank (bottom)	3.9	4510	17.6
3	O2 bottle AL248	2	0	0.0
Totals:		524.7		172.5

Table 6-3

The plot on the diagram illustrated in Figure 6-3 demonstrates that the CG is slightly forward of the mid position and borders on the maximum allowable weight.

The flying CG can be calculated as follows:

$$\text{Flying CG} = \frac{\text{Total of moments}}{\text{Total mass}} = \frac{172\,500}{524.7} = 329\text{ mm}$$

The flying CG must be within the limits given in Section 2.6.

Figure 6-3 illustrates the envelope for the 15 m configuration.

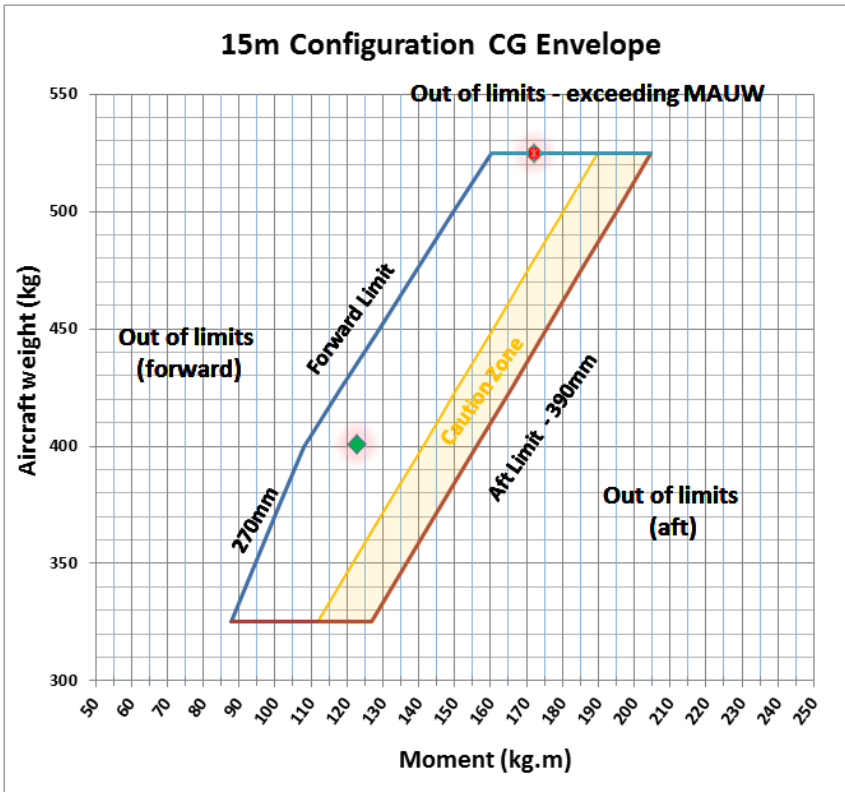

Figure 6-4

Figure 6-4 illustrates the envelope for the 18 m configuration.

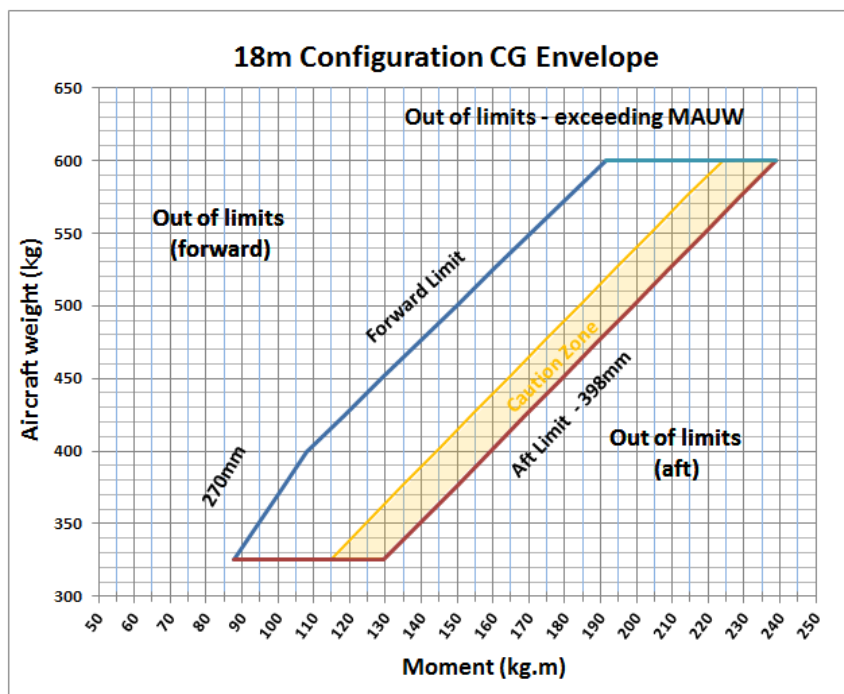

Figure 6-5

6.4 Optimisation of centre of gravity

The CG of the aircraft is shifted towards the aft 25 % of the CG to obtain optimum overall performance. The procedure to set up the CG optimally is as follows:

1. Setup the aircraft to include the pilot weight in the empty configuration on the desired CG position (75% position). This can be achieved by:
 - Add/remove the permanent ballast and perform the following:
 - Redo the mass and balance.
 - Recalculate the new minimum and maximum cockpit loads as explained in the JS-MD 3 RES Maintenance Manual.
 - Update the cockpit loads placard or Placard Booklet (Figure 2-5).
 - Update the weight and balance record (Table 6-1)
 - Add/remove the removable ballast to change the empty (no water ballast) CG. The removable ballast includes:
 - Water in the non-expendable tail tank (top fin tank).

When loading the aircraft with water ballast, the expendable tail tank is used to offset the forward CG change due to water in the main wing tanks. Calculate the water quantity required in the expendable tail tank and load accordingly.

Dumping water ballast in flight has no effect on the CG position when using this procedure.

NOTE: The removable ballast is used to change the CG (without water ballast) without affecting the approved weight and balance record.

6.4.1 Expendable tail tank

The expendable tail tank is only used to offset the CG change due to the water ballast in the main wing tanks.

	Load point	Mass		Moment arm	
		kg	lbs	mm	inch
M_{TAIL1}	Expendable tail tank	5.8	12.7	4285	168.7

Table 6-4

To offset the forward CG change due to water in the main wing tanks, the expendable tail tank must be filled according to Table 6-5:

Water in main tanks		Required water in tail tank			
		132 l Main tanks		156 l Main tanks (Optional)	
Litres	US gallons	Litres	US gallons	Litres	US gallons
0	0	0	0	0	0
20	5.3	1.2	0.3	0.8	0.2
40	10.6	2.4	0.6	1.4	0.4
60	15.9	3.5	0.9	2.1	0.6
80	21.1	4.4	1.2	2.9	0.8
100	26.4	5.2	1.4	3.7	1.0
120	31.7	5.8	1.5	4.7	1.2
140	37.0	N/A	N/A	5.6	1.5
156	41.2	N/A	N/A	5.8	1.5

Table 6-5

6.4.2 RES batteries

RES batteries are required for the retractable electric system. The aircraft can be flown with no RES batteries, with one battery or with two batteries. The required minimum cockpit weight is higher when batteries are installed.

The table below indicates the maximum weight and moment arm of the batteries.

	Load point	Mass		Moment arm		Effect on minimum pilot weight	
		kg	lbs	mm	inch	kg	lbs
M_{Batt1}	RES 400V HV battery (L)	24.9	54.9	879	34.6	+11.6	+25.6
M_{Batt2}	RES 400V HV battery (R)	24.9	54.9	879	34.6	+11.6	+25.6

Table 6-6

Refer to the minimum cockpit weights placard (or Placard Booklet) or Table 6-1 for the difference in minimum cockpit load with RES batteries installed. Figure 2-5 shows an example of this placard.

6.4.3 Non-expendable tail tank

Adding water to the non-expendable ballast tail tank moves the CG rearwards. The required minimum cockpit weight increases when water is added to the tail tank.

Table 6-7 indicates the maximum weight and moment arm of the two split non-expendable ballast tanks.

	Load point	Mass		Moment arm		Effect on minimum pilot weight	
		kg	lbs	mm	inch	kg	lbs
M_{Tail2}	Non-expendable tail tank (top)	5.0	11.0	4574	180.1	+20.2	+44.5
M_{Tail3}	Non-expendable tail tank (bottom)	3.9	8.5	4510	180.0	+15.5	+34.2

Table 6-7

Table 6-8 gives the load (litres of water) of the non-expendable ballast tail tank to achieve a CG on the suggested 75% mark.

Non-expendable tail tank load requirements to obtain optimum cg (kg)							
Pilot + Parachute		60	70	80	90	100	110
Minimum cockpit weight on placard (kg)	55			2.3	4.9	7.4	9.9
	57			1.8	4.3	6.9	9.4
	59			1.3	3.8	6.4	8.9
	61			0.8	3.3	5.9	8.4
	63			0.3	2.8	5.4	7.9
	65				2.3	4.9	7.4
	67				1.8	4.3	6.9
	69				1.3	3.8	6.4
	71				0.8	3.3	5.9
	73				0.3	2.8	5.4
	75					2.3	4.9
	77					1.8	4.3
	79					1.3	3.8

Table 6-8

The colour coding is defined as follows:

Red coloured cells

Red coloured cells indicate load conditions outside of the aft limit. Additional cockpit weight is required to fall within the CG range. Do not operate the aircraft without ensuring the CG loading is correct

Amber coloured cells

Amber coloured cells indicate that the CG falls in the caution zone (aft 25%). It is strongly recommended to adjust the loading more forward to the aft 25% position. The two options available are:

- Additional pilot weight is required to move the CG forward towards the optimum position (75% from the front position).
- Permanent ballast can be removed from the cavity in the tail, in accordance with the JS-MD 3 RES Aircraft Maintenance Manual, to reduce the minimum cockpit weight. In this case a new weight and balance must be performed.

White coloured cells

White coloured cells indicate the weight requires in the non-expendable tank to adjust the CG to the optimum aft 25% position.

Blue coloured cells

Blue coloured cells indicate the maximum weight requires in the non-expendable is insufficient to reach the optimum CG position. Refer to the CG calculator to ensure the forward CG limit is not violated.

CAUTION: Winch launching with the CG in the caution band is not recommended. Refer to Table 4-1.

CAUTION: When flying the aircraft with the CG on the forward limit with ballast in the main wing tanks and expendable rear tank, all of the ballast in the main wing tanks and the expendable tail tank must be dumped once the dumping process has started. The reason for this is that the rate of dumping of the rear expendable tank is higher than the main tank, moving the CG outside the forward limit during dumping. Once all of the ballast has been dumped the CG will return to the forward limit.

WARNING: Flying outside the allowable CG is not allowed. Moving the CG rearwards reduces the lateral stability of the aircraft and increases the likelihood to enter an unintentional spin.

6.4.4 Removable nose ballast weight

Installing nose ballast weights moves the centre of gravity forward. The required minimum cockpit weight becomes lower when nose weights are installed.

	Load point	Mass		Moment arm		Effect on minimum pilot weight	
		kg	lbs	mm	inch	kg	lbs
M_{NoseB}	Nose weights in front of pedals	12.0	26.5	-1782	-70.2	-25	-55.1

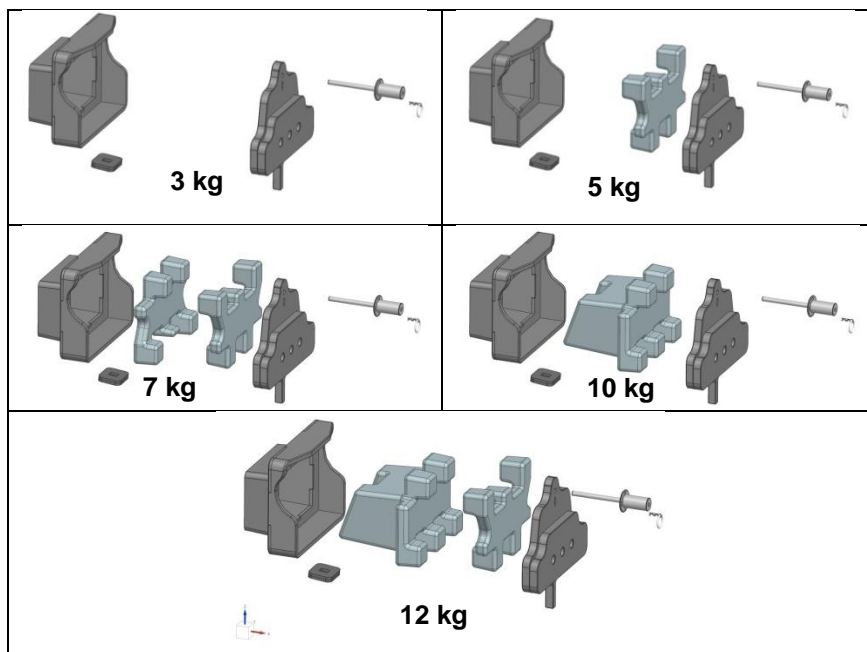

Figure 6-6

Table 6-9 indicates the required removable nose trimming weights (in kilogram) to move the CG into a permissible range.

Nose trimming weights requirements to move cg into allowable envelope (kg)											
Pilot + Parachute		55	60	65	70	75	80	85	90	95	
Minimum cockpit weight on placard (kg) for number of HV batteries installed	72	8	6	4	1		CG within limits- water may be added to non-expendable tail tank to optimize CG				
	74	9	7	4	2	0					
	76	10	8	5	3	0					
	78	11	9	6	4	1					
	80	12	9	7	5	2					0
	82		10	8	6	3					1
	84		11	9	7	4	2	0			
	86		12	10	8	5	3	0			
	88			11	9	6	4	1			
	90		Outside CG limits	12	9	7	5	2	0		
	92	10		8	6	3	1				
	94	11		9	7	4	2	0			
96	12	10		8	5	3	0				

Table 6-9

7 System description

7.1 Introduction

Section 7 gives a description of the aircraft systems as well as for instructions on the use thereof. A detailed technical description of the systems with drawings can be found in the JS-MD 3 RES Aircraft Maintenance Manual.

The main aim of this section is to describe the controls, their labels and layout in the aircraft.

7.2 Cockpit controls

7.2.1 Elevator and aileron

The elevator and ailerons are controlled conventionally by the control stick. Forward-aft movement deflects the elevators while sideways movement deflects the flaperons in the desired direction.

Various stick grip options are available with integrated instrument control buttons or just the radio transmit button (press-to-talk).

A leather boot covers the bottom of the stick. This boot must always be in position to prevent foreign objects from entering the control circuit below the cockpit seat pan.

The wheel brake is activated by squeezing a trigger on the control stick illustrated in Figure 7-1.



Figure 7-1

7.2.2 Rudder

The rudder is controlled by the rudder pedals in the front section of the fuselage. Pushing either pedal deflects the rudder in the desired direction.

The rudder pedals' fore and aft position is adjustable to accommodate different size pilots. The ergonomic controller on the right-hand side of the cockpit is used to make adjustments either on the ground or during flight.

CAUTION: If an electrical failure results in an uncommanded movement of the rudder pedals, disconnect the power from the rudder actuator circuit by pulling the “Elect” fuse on the instrument panel.

7.2.3 Flap

The flap control (Figure 7-2) is via a black handle located on the left-hand side of the cockpit. The flap handle can be freed from its detent by rotating it slightly clockwise as seen from the rear.



Figure 7-2

The flap setting is indicated on the flap indicator plate (Figure 7-3), positioned just above the flap handle. It has six graduations, namely flap settings 1, 2, 3, 4, 5 and L. Setting 1 is the most negative setting and setting L is the most positive setting.

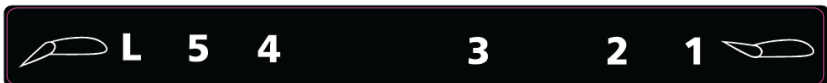

Figure 7-3

7.2.4 Release system

The nose and CG hooks are operated simultaneously when the release handle is pulled towards the pilot.

The release handle is a yellow handle positioned on the left-hand cockpit side in front of the flap handle (Figure 7-4).

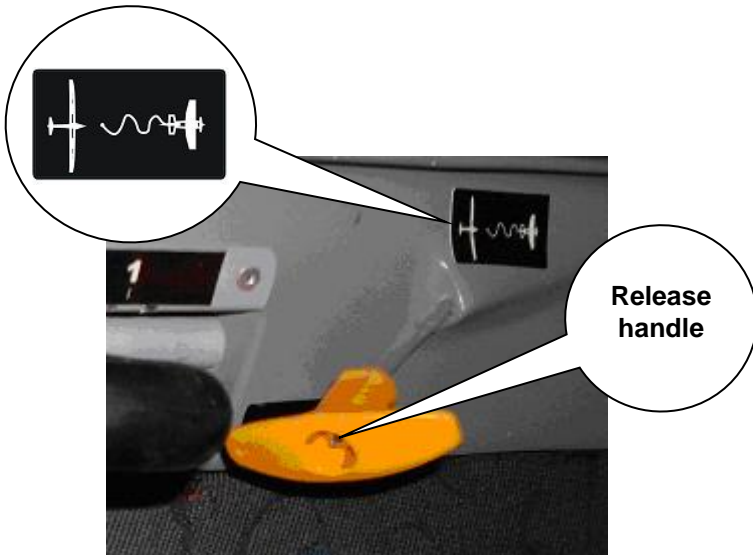

Figure 7-4

7.2.5 Trim

The trim of the aircraft is adjusted with a green knob located on the left side of the cockpit below the airbrake lever. The trim can be adjusted when the trim knob is pressed downwards.

Moving the trim knob has the following effect on the elevator control:

- Forward: Nose down force
- Backwards: Nose up force

The trim locks in the set position when the downward pressure on the knob is released.

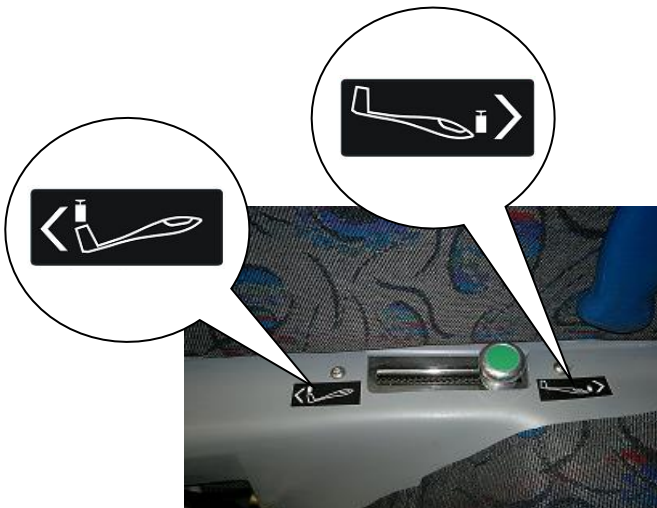

Figure 7-5

7.2.6 Ergonomic control

7.2.6.1 Rudder pedal adjustment

The rudder pedals adjust electrically.

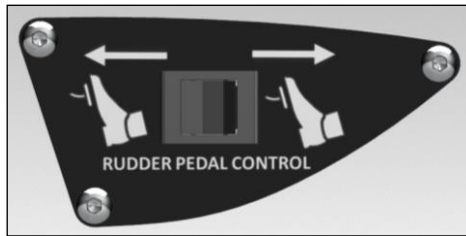

Figure 7-6 Rudder pedal control panel

Adjust the pedal position using the control switch as follows:

- Forward: Moves the rudder pedals away from the pilot
- Backward: Moves the rudder pedals closer to the pilot

7.2.6.2 Heated boots

A 12V output plug can be optionally installed to power heated boots or any other 12V device. This power plug is located on the instrument console.

7.2.6.3 Seatback adjustment

The bottom of the seatback can be moved forwards and rearwards by removing two thumb screw knobs on the seatback pivot point and setting the seatback to the desired position (Figure 7-7).



Figure 7-7: Seatback lower adjustment

The top of the seatback can be adjusted between an upright or reclined position by moving the seatback adjuster located behind the seatback. The seatback adjuster is unlocked by lifting both lock pins up and letting them rest in the slot (Figure 7-8).

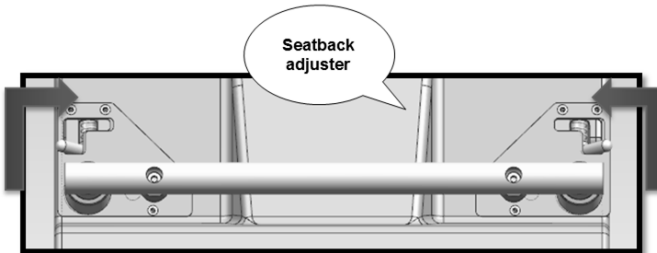

Figure 7-8: Seatback upper adjustment

WARNING: Ensure that both thumbscrews and the adjuster locking pins are engaged before flying to prevent the pilot from shifting backward. This could result in loss of aircraft control.

7.2.6.4 De-misting control (manual option)

For aircraft without the ergonomic control system, the cabin and demisting ventilation system is manually adjustable via an organ stop on the instrument panel.

To adjust the ventilation, push or pull the organ stop as follows:

- Pulling the organ stop towards the pilot increases airflow.
- Pushing the organ stop towards the instrument panel decreases airflow.



Figure 7-9: De-misting valve open



Figure 7-10: De-misting valve closed

The eyeball vent positioned on the right-hand cockpit sidewall is manually adjustable to direct the airflow as desired. Closing the eye ball with the ventilation open will still allow air to flow over the instrument binnacle.

7.2.6.5 Cabin ventilation control (manual option)

For aircraft without the ergonomic control system, the eye ball vent positioned on the right-hand cockpit sidewall is used to direct the airflow as desired, and to regulate the airflow rate (Figure 7-11).



Figure 7-11: Cockpit ventilation

7.2.6.6 Cabin ventilation control (electrical option)

For aircraft equipped with the ergonomic control system, the cabin ventilation system is electrically adjustable via the ergonomic control panel.

To adjust the ventilation, rotate the selector switch to select either the eyeball vent or demisting function. Adjust the ventilation using the control switch as follows:

- Up (+): Increases airflow
- Down (-): Decreases airflow

The eyeball vent, positioned on the right-hand cockpit sidewall, is used to direct the airflow as desired and may also be used to regulate the airflow rate (Figure 7-11).

NOTE: Both the cabin and demisting ventilation system open and close reasonably fast. Only short clicks on the control switch are needed when either fully opened or fully closed is required.

7.2.7 Instrument panel

The instrument panel is integral with the canopy and lifts to facilitate entering and exiting from the aircraft. The canopy can be removed from the instrument console by supporting the canopy and pulling back on both red jettison levers on the sides of the canopy frame.

The instrument layout is designed according to the owner's requirements and approved by the manufacturer. There are various options that the customer can choose from.

Identification of instruments, switches and circuit breakers installed on a custom designed instrument panel is illustrated in Figure 7-12. Refer to Section 2.11 for the minimum instruments required as part of the minimum equipment list.



#	Description
1	Fire warning indicator
2	RES Master ON/OFF and 12V battery selector switch (Figure 7-25)
3	RES Control and display unit
4	Circuit breakers
5	Master switch arrangement (Figure 7-24)

Figure 7-12: Custom instrument panel layout

7.3 Landing gear system

The landing gear handle is located on the right-hand side of the cockpit and labelled as illustrated in Figure 7-13. Pulling the handle backward retracts the landing gear and pushing it forward extends the landing gear. The handle is rotated firmly clockwise to lock the landing gear in the extended and retracted position.

If a retractable tail wheel is fitted, the retractable tail wheel is extended mechanically with the main gear. When the main wheel is retracted, a spring retracts the tail wheel.

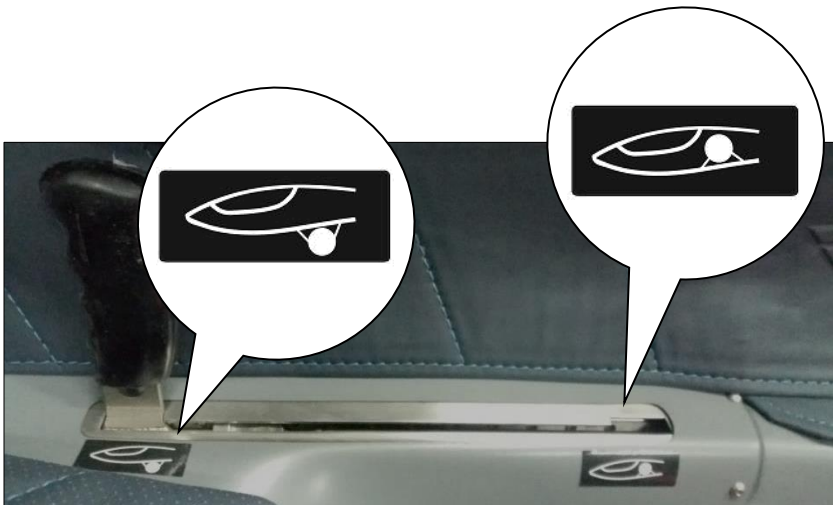

Figure 7-13

7.4 Seats and safety harness

The safety harness is a four-point system. The lower straps pass through the seat pan and are anchored to the fuselage skin. The shoulder straps pass through the seatback and are attached to the structure behind the pilot's shoulders.

CAUTION: Shorter pilots should add firm cushions (preferably energy absorbing cushions) on the seat pan to raise the body position in the cockpit. The cushion height should be sufficient to ensure that the shoulder straps pull the pilot down positively.

WARNING: No compressible cushions behind the pilot's back are allowed. A forward acceleration (e.g. a winch launch) may prevent the pilot reaching the controls safely if the cushions are of a compressible type.

The seat upper and lower seat back can be adjusted mechanically. See Section 7.2.6 for more details.

7.5 Pneumatic system

The aircraft pneumatic system consists of:

- Static (P_{STAT}) piping for the ASI and altimeter
- Dynamic (P_{TOT}) piping for the ASI
- Static piping for the variometer from fin probe
- Total energy (TE) piping from the fin probe

The pneumatic piping is colour coded as follows:

Pneumatic piping	Colour
Static for the ASI and Altimeter	Blue
Dynamic for the ASI	Green
Static for the electronic flight computer from the multi-probe	Transparent/ White
Total energy from the fin probe	Red
Mechanical variometer capacity	Yellow

Table 7-1

Figure 7-15 gives a schematic of the instrument layout.

NOTE: The ASI must use the static sources located in the rear of the fuselage tube. The airspeed calibration values are based on these static port readings.

NOTE: Static ports located in the rear of the fuselage tube is marked with a red ring and must be kept unobstructed to ensure correct ASI readings.

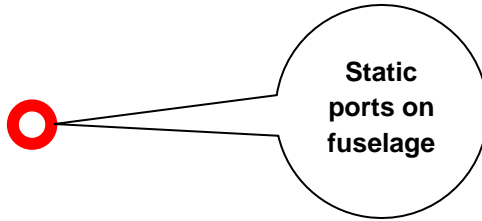

Figure 7-14

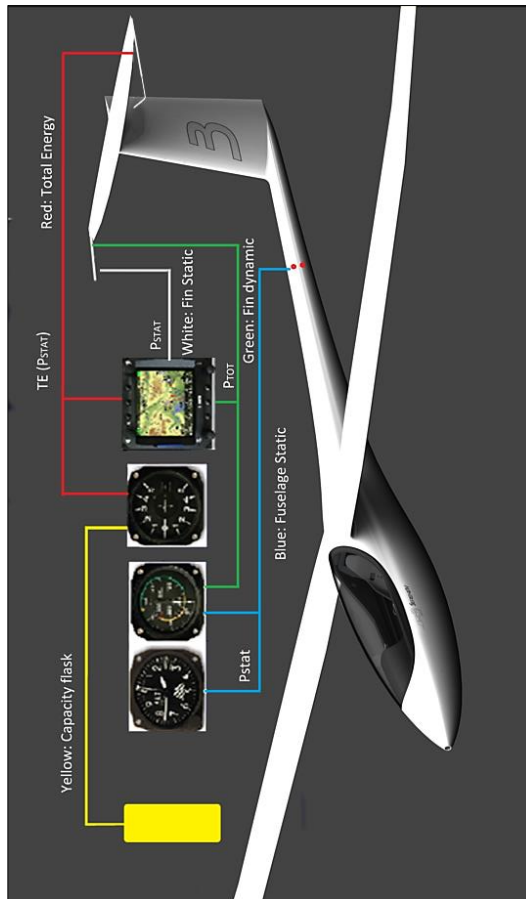

Figure 7-15

7.6 Airbrake system

The airbrakes are actuated by the blue handle on the left-hand side of the cockpit (Figure 7-16).

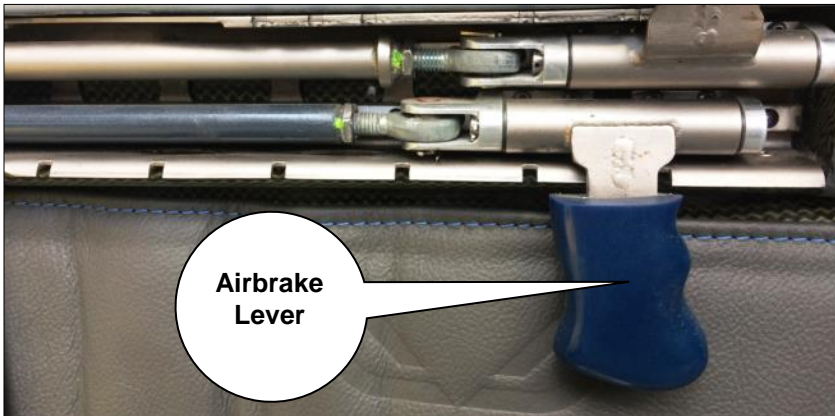

Figure 7-16 Airbrake Lever

The airbrakes are operated as follows:

- Pull the handle backward to open the airbrakes. Figure 7-17 illustrates the cockpit label for the open airbrake position.
- Push the airbrake lever forward to close the airbrakes. Figure 7-18 illustrates the cockpit label for the closed airbrake position.



Figure 7-17



Figure 7-18

The airbrakes can be locked in four different positions during flight. This is achieved by rotating the lever downwards into the detents.

The airbrakes are locked by moving the airbrake handle fully forward, over the over-centre lock. A force of approximately 15 to 20 kg is required to lock the airbrakes.

A damper restricts the rate of opening to reduce high loads on the aircraft if the airbrakes are opened at high speed.

CAUTION: The airbrake caps may oscillate at speeds between 100 and 130 km/h when opened at approximately 20mm. Avoid prolonged airbrake settings where the caps are oscillating.

WARNING: When closing the airbrakes ensure the airbrake lever is fully forward and locked over-centred. The first detent position is not the fully closed position.

7.7 Baggage compartment

The baggage compartment of the JS3 RES is utilised for the controller cooling system.

CAUTION: Ensure no items obstruct the cooler intake port when RES is installed.

For the pure glider (with no RES installed) the following applies for the baggage compartment:

The maximum weight of items in the baggage compartment is 1 kg. This should only be used for soft items that will not injure the pilot in the event of a hard or crash landing. Ensure that the 12V batteries stored in this area are secured with the battery straps and thumb screws. Ensure that the airflow holes in the rear are not obstructed as this might lead to a reduction in performance of the aircraft.

7.8 Water ballast system

7.8.1 General

The water ballast system allows the weight of the aircraft to be increased to a maximum of 525 kg (1157 lbs) in the 15 m configuration and to 600 kg (1322 lbs) in the 18 m configuration. For self-launching with two HV batteries installed, the weight can be increased to a maximum of 525 kg (1157 lbs) for the 15 m configuration and 575 kg (1267 lbs) for the 18 m configuration. The water tanks are integral to the wings. Each inboard wing tank holds approximately 66 litres (or 78 litres optional) of water. Each 18 m wingtip holds approximately 17 litres of water. The 15 m outboard wings have no integral water tanks.

There are two tail tanks to enable the pilot to set the optimum CG position for flight:

- The expendable ballast tail tank is positioned in the front area of the vertical fin with a capacity of approximately 5.8 litres.
- The non-expendable ballast tail tanks are positioned in the rear area of the vertical fin and have a combined capacity of approximately 8.9 litres. This tank is used to optimize the un-ballasted CG position.

The water in the non-expendable ballast tanks can be drained after flight by removing the tape over the holes on the left-hand side of the fin.

The dump valve control is situated on the right-hand side of the cockpit. Pushing the lever forward opens both the wing tank valves and the expendable tail tank valve.

Moving the dump valve control in the full forward position opens also the 18m outboard wing tank valves.

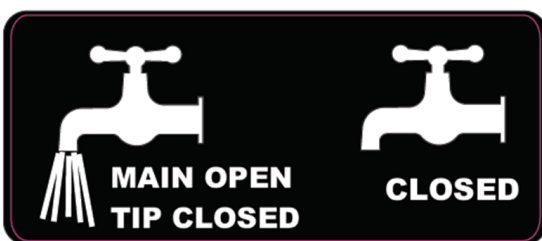
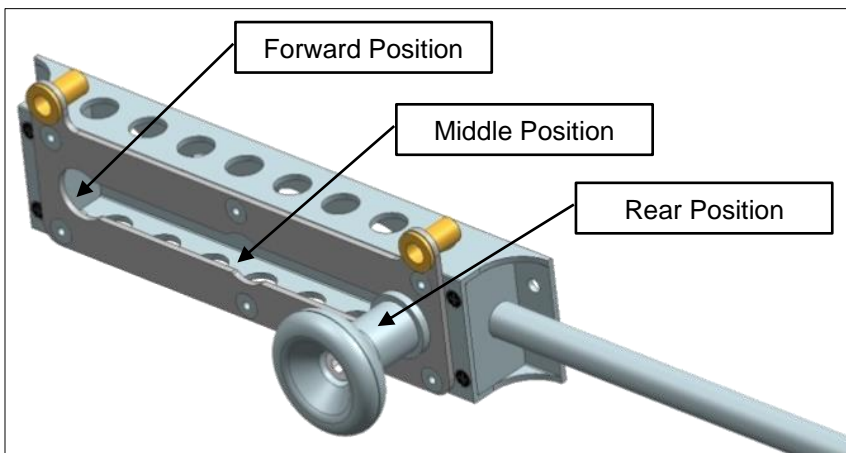

Figure 7-19

CAUTION: When dumping water, first dump water in the main tanks before dumping the tip tanks.

7.8.2 Main tanks

The main tanks are integrated into the D-box area of the main wings (inboard section), spanning the entire leading edge of the wing, as illustrated in Figure 7-20.

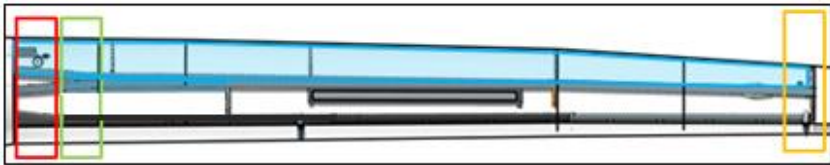

Figure 7-20: Main wing tanks (blue)

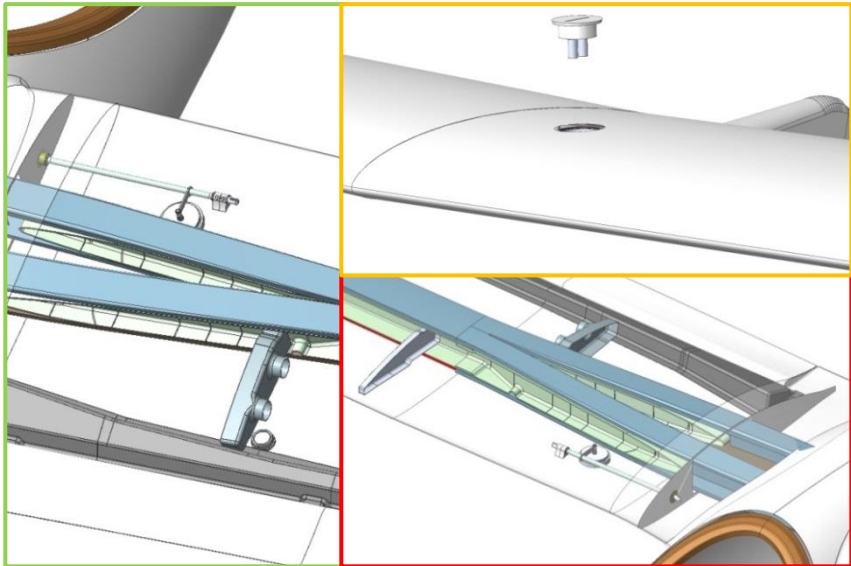

Figure 7-21: Main wing water tank filler and drain cap locations

The dump valves are situated in the lower wing skin, approximately 400 mm from the fuselage.

7.8.2.1 Filling the main tanks

The filling holes are positioned on the top of the inboard wing section near the tip junction.

Filling is done through the top filling holes. The filling holes are closed by screwing the filler caps into position using the universal rigging tool.

The main tanks are vented through the vent holes in the filler caps. Vent caps fitted with specially designed one-way valves will reduce water spillage through the filler caps when a wing is lowered.

NOTE: The filler caps used on the main wing must be fitted to the one-way valves.

CAUTION: The filling pipe diameter should preferably not exceed 12mm (0.5"). Water tanks may burst under high water pressure if the filling pipe is left unguarded in the filling hole without sufficient venting area around the pipe.

7.8.2.2 Draining the main tanks

Water can be dumped from the main tanks by moving the dump valve control in the centre or full forward position.

Approximately 200 ml of water remains in the tank after dumping. This water must be drained after flight. Draining can be done as follows:

- Remove the main wing and subsequently remove the red drain plug from the root.
- Lift the tip of wing panel with the leading edge facing downwards and allow all the water to drain.

7.8.3 18 m Tip tanks

In the 18 m configuration water is also carried in the outboard wings. Each outboard wing additionally carries approximately 17 litres of water.

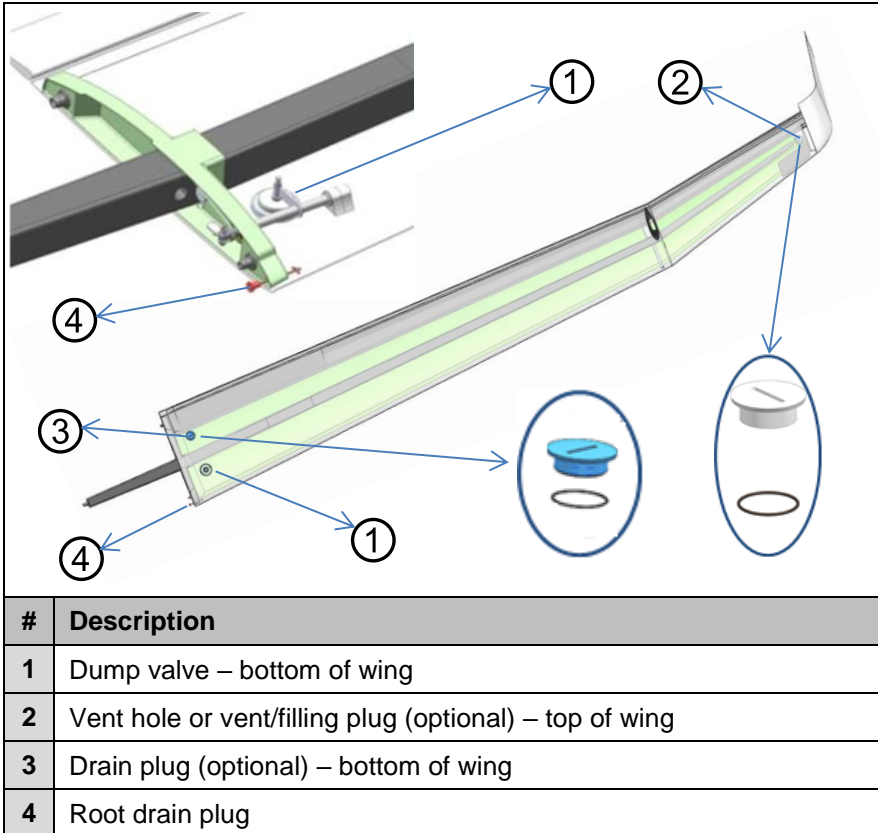

Figure 7-22: 18m outboard tanks

Figure 7-22 illustrates the water tanks, dump valve, vent hole (or vent/filling plug) and root plug of the 18m outboard wings.

7.8.3.1 Filling the tip tanks

Filling of the 18m tips is done through the filling hole on the 18m tips. The filling holes are closed by screwing the filling caps into position using the universal rigging tool.

CAUTION: The filling pipe diameter should preferably not exceed 12mm (0.5"). Water tanks may burst under high water pressure if the filling pipe is left unguarded in the filling hole without sufficient venting area around the pipe.

NOTE: The filling plug on the 18m tips can be either a plug with two holes (same as inner wing filler plug without one-way valves) or a plug with a single hole. Filler caps with one-way valves are not permitted as venting in both directions is required.

7.8.3.2 Draining the tip tanks

Water can be dumped from the tip tanks by moving the dump valve control in the full forward position.

Approximately 200 ml of water remains in the tank after dumping. This water must be drained after flight. Draining can be done as follows:

- Remove the 18m outboard tip and subsequently remove the red drain plug from the root. Lift the tip of wing panel with the leading edge facing downwards and allow all the water to drain.
- If a drain plug is installed, removed while the glider is rigged to drain the remaining water.

CAUTION: It is important to leave the dump valves, filler caps and drain plug open during storage. This allows the tanks to ventilate and reduce water absorption in the composite structure. Long term exposure to internal moisture results in undesired deformation of the wing profile.

7.8.4 Water tanks in fin

There are two water types of ballast trim tanks in the fin of the JS-3 RES, an expendable tank ahead of the shear web and non-expendable tanks behind the shear web.

7.8.4.1 Expendable water ballast

The expendable water ballast in front of the fin shear web is used to offset the CG change due to the water ballast in the main inboard wing tanks.

The tail tank must be filled according to the procedure provided in Paragraph 4.5.7.1.

Draining the tail tank is done by moving the single water dump lever to the centre or forward position.

7.8.4.2 Non-Expendable water ballast

The non-expendable water ballast tanks located behind the shear web in the fin are not expendable and are used to trim the CG position for pilot weight.

Filling is done through the filling hole on the left side of the fin.

These must be filled according to the procedure provided in Paragraph 4.5.7.1.

Draining is done by removing sealing vinyl stickers from the bottom hole on left hand side of fin. Opening more holes will accelerate the dumping process.

NOTE: Vinyl stickers with a diameter not less than 25mm should be used to seal the hole on the fin.

The non-expendable tank is divided into two tanks as illustrated in Figure 7.8-7. Both tanks must be filled to reach total capacity. Both tanks must be drained by removing sealing vinyl stickers from the bottom hole(s).

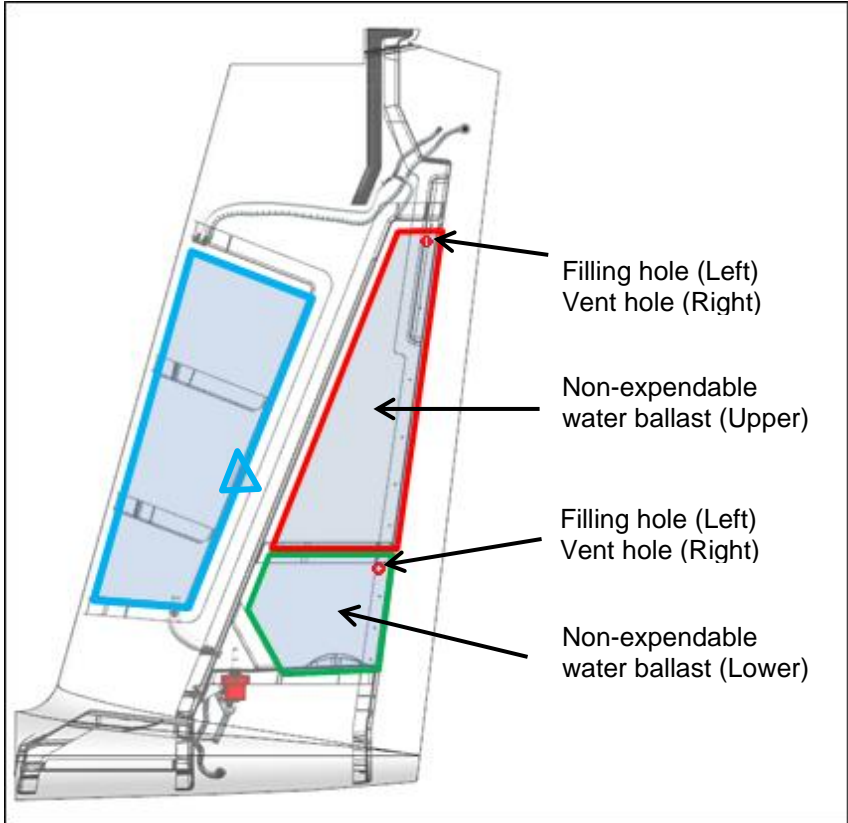

Figure 7-23

7.9 Power plant

Refer to section 8.2 in the JS-MD 3 RES Flight Manual Supplement.

7.10 Fuel system

NOT APPLICABLE

7.11 Electrical system

The electrical power of the aircraft is supplied by maintenance-free dry-gel type or LiFePO-4 12V batteries. One battery is fitted below the seatpan (F) and the other battery is fitted behind the seatback (R).

Power is supplied to the various electrical systems with a battery master switch arrangement and battery selection switches.

CAUTION: Overload protection is provided for each electrical system by circuit breakers. The rating for each system must comply with the specifications of the equipment manufacturer.

7.11.1 Electrical system description

12V DC Power is supplied to three separate electrical systems:

1. Avionic Bus
2. Electrical system (Rudder pedals adjustment, Bugwipers etc.)
3. RES (Retractable Electric System)

7.11.1.1 Master switch arrangement

A master switch arrangement is used to switch on the avionic system and electric system.



Figure 7-24 Master Switch

7.11.1.2 Power source selection

Battery selection for the avionics and electrical systems are on the switch arrangement, allowing selection between Battery 1 (F) or Battery 2 (R).

Dividing the avionics and electrical system into separate systems allows the pilot to supply power from separate batteries or from the same source.

The following systems are typically powered by the avionics and electrical busses:

1. Avionic Bus:
 - VHF radio
 - Primary flight computer
 - Primary logger
 - Transponder (if fitted)
 - Secondary flight computer
 - Secondary logger
2. Electrical Bus:
 - Rudder pedal controller
 - Bug wiper system
 - 5V power supply
 - Warning systems (if fitted)

7.11.2 Power plant electrical system description (if fitted)

12V power to the RES can be selected from either the front or rear avionics battery. This is achieved by selecting the appropriate battery on the RES master switch arrangement.



Figure 7-25 RES master switch and 12 battery selector

Refer to section 8.3 in the JS-MD 3 RES Flight Manual Supplement for more information on the electrical system.

7.11.3 Recommended battery types

The batteries used in the aircraft must be of the dry sealed type, as no battery that vents any gas is allowed in the aircraft according to the airworthiness requirements of CS-22.

Front battery: 12V LiFePO4 (10 Ah to 12.5 Ah)
 Dimensions: 80 mm x 54 mm x 138 mm
 Fuse required for Avionics & RES: 25 A

Rear battery: 12V LiFePO4 (9.9 Ah)
 Dimensions: 190mm x 143.6 mm x 36 mm
 Fuse required for Avionics & RES: 25 A

RES batteries: Emeetric 96-4 400V

NOTE: Either the front or rear 12V avionic batteries can be used to power the RFU / RES-DCU. It is advised to run all avionics from one battery, leaving the other battery to power the RFU / RES-DCU and electrical systems.

WARNING: Only use batteries supplied with aircraft or supplied by manufacturer. These batteries have circuit breakers at the terminals for overload protection and to protect the terminals from possible short circuits.

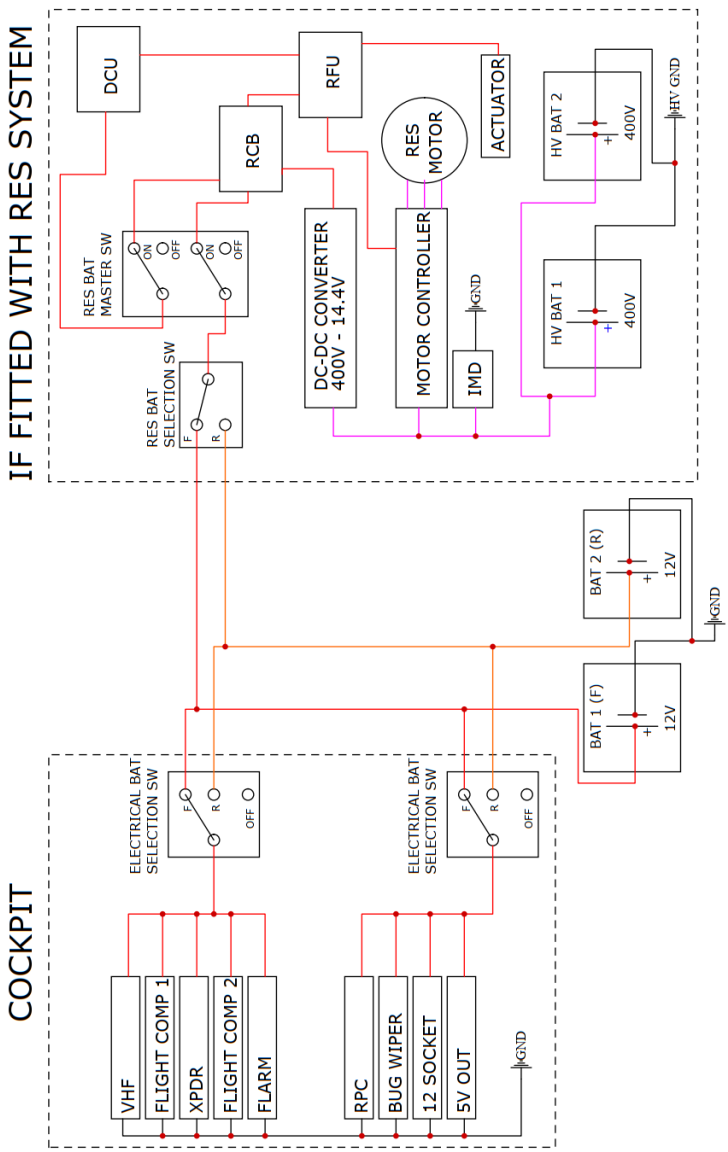

Figure 7-26 Master switch arrangement

7.12 Miscellaneous equipment

7.12.1 Microphone and antenna

The plugs for microphone and antenna from the canopy frame are behind the instrument panel.

CAUTION: The radio microphone is located on the canopy frame. Take care when removing the canopy from the instrument panel. The microphone plug should be carefully unplugged to avoid damage to the cables.

7.12.2 Oxygen

Provision is made for an oxygen bottle on the left-hand side of the cockpit behind the seatback. If an oxygen bottle is used, ensure that it is secured properly using the locking bracket.

7.12.3 Bug wiper system

The bug wiper controls can be found on the left side of the cockpit in front of the trim lever.

If the bug wiper system is installed, perform the following checks before each flight:

- Check the operation of the bug wiper winding system. Ensure that the wipers are set to wipe not closer than 500 mm from the winglet.
- Check that both wipers sit correctly in their garages when retrieved.
- Check the condition of the wiping cable and retrieve cable.
- Check that the stabilizing leg of the wiper opens between 70° and 90°.
- Check that the gaps between the fuselage and wings and between wing sections are correctly bridged. While wiping the wiper cleaning filaments may get caught in the gaps if not covered correctly. A suggested method to cover the gaps between panels is illustrated in Figure 7-27.

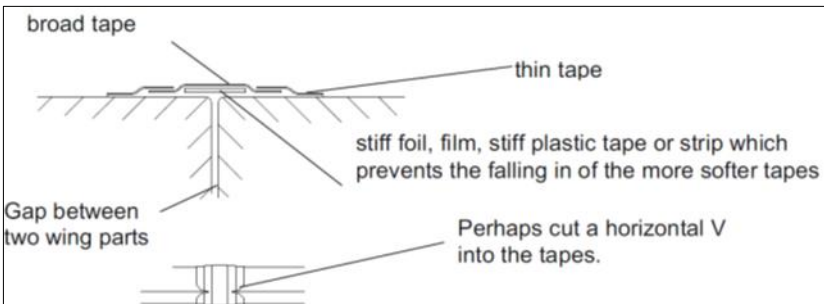

Figure 7-27

8 Handling and maintenance

Certain inspections and maintenance procedures to maintain aircraft performance and reliability are included in this section. It is advisable to follow a regular schedule of lubrication and preventive maintenance, consistent with the usage, climatic and flying conditions encountered.

For service and information not contained within this manual, it is recommended that the agent or manufacturer be contacted. All correspondence regarding the aircraft should carry its serial number.

The serial number can be found in the cockpit behind the back rest on the right-hand side of the fuselage.

For more information regarding handling and maintenance refer to the appropriate sections of the JS-MD 3 RES Aircraft Maintenance Manual (AMM and its supplement) and the Aircraft Flight Manual supplement (AFM supplement).

8.1 Aircraft inspection periods

The aircraft shall be subjected to an annual airworthiness inspection. A more detailed inspection schedule can be found in the JS-MD 3 RES Aircraft Maintenance Manual.

- Airworthiness inspections must be performed in accordance with the relevant laws of the country in which the aircraft is registered.
- The manufacturer recommends performing a daily inspection, pre-flight check and cockpit checks as specified in Section 4.
- The manufacturer recommends performing additional inspections in certain circumstances (such as hard landings or ground loops) as explained in the JS-MD 3 RES Aircraft Maintenance Manual.
- Other inspections, maintenance or modifications to the aircraft, components or systems may be classified as “Mandatory” or “Recommended” according to issued Airworthiness Directives and Service Bulletins (SB).

NOTE: It is the responsibility of the owner/operator to ensure compliance with all applicable Mandatory Airworthiness Directives.

- Personnel performing inspections and maintenance must be properly qualified in accordance with the relevant laws of the country in which the aircraft is registered.

8.2 Ground handling

8.2.1 Ground towing

Either use a rope or other non-metallic cable from the nose hook with someone walking with the wing tip, or

Use a tow bar connected to the tail dolly and a 'wing walker' with a sprung wheel (or someone walking with the wingtip).

CAUTION: Never tow the aircraft faster than walking pace.

WARNING: Do not push or pull on the wingtips.

8.2.2 Supporting area for road transport

1. Fuselage:

- Tail skid or tail wheel (with tail wheel fairing removed)
- Main wheel
- Shell in front of landing gear, minimum length of support 300 mm

2. Wing:

- Main spar at main pin hole closest to the root rib
- Skin at root rib, minimum width of support 150 mm
- Skin at 7.5 m, minimum width of support 250 mm

3. Tailplane:

- Anywhere on the skin, minimum width of support 80 mm

WARNING: The flaperon sandwich construction can be damaged if excessive force is used and should be handled with care.

WARNING: The removable tail wheel fairing can be damaged if not removed for road transport

8.2.3 Tie down

The aircraft can be tied down using the holes in the wingtip skids. It is preferable to position wing stands under the wings inboard of the tip junction adjacent to the tie down ropes. A tie down rope across the rear fuselage boom in front of the fin should also be used to prevent the tail from lifting. It is advisable to restrain the rudder. Always tape the airbrake caps closed if there is a possibility of rain and remember to remove tape during the pre-flight inspection.

NOTE: It is recommended to use brightly coloured tape to tape the airbrake caps.

8.3 Cleaning and care

8.3.1 General

The JS-3 RES is manufactured from a composite of glass, carbon and aramid fibres in an epoxy matrix. The gel coat surface layer is finished with a polyurethane acrylic 2K paint topcoat.

There is no composite material available that is impervious to moisture absorption or to UV (ultra-violet) rays. UV rays will break down the epoxy matrix cross links and moisture absorption will damage the bond between the epoxy and the fibres, ultimately degrading the structural integrity of the aircraft. The utmost care must be taken to ensure that the structure of the aircraft is kept dry and not exposed to moist, hot or humid environments for protracted periods.

8.3.2 Paint and gel coat

The purpose of the outer surface finish is to present a good aerodynamic surface to the air when flying, but also to protect the structure from the environment. The main enemy of the structure is UV rays and moisture. UV rays will break down the epoxy cross links and will destroy the structural integrity of the aircraft. Gel coat protects the structure in a self-sacrificing fashion. The gel coat will degrade while protecting the structure. This will appear as cracks and yellowing. The gel coat can be protected by refinishing the aircraft with a Polyurethane Acrylic 2K paint system (factory finish process). Applying hard wax will not prevent UV damage to the gel coat, but will slow down the surface deterioration.

Clean the outside of the aircraft with water and a mild detergent. Never use acetone or lacquer thinners to remove tape residue; rather use a silicon-free polish. Immediately after washing the aircraft dry it off with a soft chamois. Use special care not to allow water to get into the hinge line and airbrakes.

CAUTION: Never use any of the following products on the aircraft:

- Trichloroethylene
- Carbon tetrachloride or similar hydrocarbon chlorides
- Any product containing silicon

8.3.3 Canopy

The canopy must be protected from scratches. Always wash off dust by using liberal amounts of water with a soft chamois, taking care not to allow dust to get between the chamois and the canopy surface. Dry with a clean chamois. The canopy can be polished with a non-abrasive canopy polish with a rating of 5000 grid or higher.

Never clean the canopy with acetone or lacquer thinners as this will instantly create micro-cracks. Contact the manufacturer or representative for recommended canopy polishes.

8.3.4 Cockpit interior

The inside of the cockpit can be cleaned with mild soap and water.

8.3.5 Water tanks

The aircraft should always be stored with the wing tanks open to ventilate. It would be ideal to also install a small electrical fan on top of the wing surface over the water filler hole to force the ventilation of the tank. This will allow the structure to dry completely and prevent any issues due to moisture absorption.

The O-rings on the water tank filler caps must be replaced if they start to age and crack. If the wing valves leak, the most probable cause is foreign matter below the valve seal and sealing ring. Wiping the area may solve the problem. The valve seal may also be cracked in which case a replacement can be obtained from the manufacturer. The seal can be replaced with some difficulty without removing the valve mechanism.

8.3.6 Pins, bushes and control systems

All bare metal surfaces that are not protected with paint must be protected with a thin film of grease.

8.3.7 Seat belt harness

The seat belt harness must be checked regularly for frayed off edges, mildew and wear.

The fittings and buckles must be checked regularly for corrosion and proper functioning. Also refer to the seat belt harness manufacturer's maintenance instructions.

8.3.8 Tow release

Clean the nose and CG hooks regularly by means of pressured air and lubricate with spray oil. Also refer to the maintenance manual of the manufacturer.

8.3.9 Longitudinal push rod bearings

Linear bearings are used throughout the wing control system for the airbrakes, flaperon and elevator control systems.

These bearings must never be greased or oiled. The oil and grease will pick up dust and foreign matter that will destroy the soft surface of the plastic balls.

8.4 Long-term storage

8.4.1 To store the aircraft for periods exceeding 12 months, the following is recommended:

1. Remove the instruments and store separately.
2. Close the external pressure ports and inner tube end.
3. Protect all metal parts using acid-less spray oil or non-corrosive grease (Vaseline).
4. Close all orifices without preventing air circulation using wire cloth or similar means to prevent small animals from entering.
5. Drain all water tanks and force-ventilate the water tanks until the inner surfaces of the tanks are dry. Remove the water filler caps and keep the valves open during storage.
6. Leave the airbrakes unlocked on the ground (either rigged or de-rigged) to avoid unnecessary loads on the airbrake caps.
7. Store in an as-dry-as-possible environment.

8.4.2 Return to service:

Perform at least the same inspection as for the annual inspection. A typical inspection is included in the JS-MD 3 RES Aircraft Maintenance Manual.

Inspect the wings and fuselage for small animals or nests and inspect the pneumatic system for blockage due to nests of insects.

9 Supplements

9.1 Introduction

This section includes additional information on the safe operation of the aircraft if fitted with ancillary equipment not included as standard in the aircraft.

9.2 List of ancillary equipment

9.2.1 Oxygen system

Provision is made for an oxygen bottle with a maximum diameter of 86 mm (3.4"). The oxygen bottle tube is installed through the bulkhead on the left-hand side of the wheel box. The oxygen bottle must be correctly secured with the bracket provided.

Oxygen equipment installed:

1. Must be approved.
2. Must be free from hazards in itself, in its method of operation, and its effect upon other components.
3. Must have means to allow the pilot to readily determine, during flight, the quantity of oxygen available.
4. The pilot must be able to safely monitor and operate the system.

Intentionally left blank

10 Service bulletins

This section starts with an overview table of all optional SB's, in which the owner or operator should mark which SB's he voluntary implemented and which not.

All implemented optional SB's have to be printed and added to this section by the owner or operator. SB's not implemented do not need to be added to this section.

SB No.	Rev	Date	Description	SB implemented	
				Yes	No

Intentionally left blank

Intentionally left blank

12 Contact

12.1 Type Certificate Holder

M&D Flugzeugbau GmbH & Co. KG

Streeker Straße 5b
26446 Friedeburg
Germany

☎ +49 (0) 4465 / 97878 – 11

Mail: info@md-flugzeugbau.de

12.2 Manufactured by

M&D Flugzeugbau GmbH & Co. KG

Streeker Straße 5b
26446 Friedeburg
Germany

☎ +49 (0) 4465 / 97878 – 11

Mail: info@md-flugzeugbau.de

Intentionally left blank